



Construction

Vertical multi-stage pumps with suction and delivery connections of the same diameter and arranged along the same axis (in-line).

Corrosion-resistant bearing sleeves lubricated by the pumped liquid.

MXV-E (AISI 304) Internal parts in contact with the liquid in chrome-nickel stainless steel 304, with pump casing and upper cover in cast iron for MXV-E 50-65-80.

MXVL-E (AISI 316L) Internal parts in contact with the liquid in Cr-Ni-Mo AISI 316L, including pump casing and upper cover for MXVL-E 50-65-80.

Applications

Building services pressure boosting.

Water supply to multi-storey buildings.

Washing plants.

Industrial pressure boosting systems.

Performance curve adjustment for industrial system application.

Operating conditions

For clean non-explosive liquids, without solid, filamentary or abrasive matter (with adaptation of sealing materials on request).

Temperature of liquid: from -15 °C to +110 °C.

Operating environment temperature: up to 0 ÷ 40 °C.

Maximum permissible pressure in pump casing: 25 bar.

Materials (wetted parts)

Component	MXV-E (AISI 304)	MXVL-E (AISI 316L)			
25,32,40	Flange	Cr-Ni steel 1.4301 EN 10088 (AISI 304)	Cr-Ni-Mo steel 1.4404 EN 10088 (AISI 316L)		
	External jacket				
	Suction casing				
	Delivery casing				
	Stage casing				
	Impeller				
	Lower cover				
	Upper cover				
Spacer sleeve					
50,65,80	Pump casing	Cr-Ni steel 1.4301 EN 10088 (AISI 304)	Cr-Ni-Mo steel 1.4404 EN 10088 (AISI 316L)		
	Upper cover			Cast iron GJL 250 EN 1561	
	External jacket				
	Stage casing				
For all types	Impeller	Cr-Ni steel 1.4305 EN 10088 (AISI 303)	Cr-Ni-Mo steel 1.4404 EN 10088 (AISI 316L)		
	Spacer sleeve				
	Pump shaft				
	Plug				
	Bearing sleeve/ Bearing in stage casing			Corrosion-resistant, cemented carbide/ Ceramic alumina	
	Mechanical seal ISO 3069 - KU			Hard metal/Carbon/EPDM	
	Wear ring			PTFE	
	O-rings			NBR	

Inverter-Motor

Rated speed of rotation (50/60 Hz): max n = 2900 rpm

Inverter supply: three-phase 380-480 V ± 5%, 50/60 Hz.

2-pole induction motor.

Construction IM B5.

Insulation class F.

Protection IP 55.

Special features on request

- Special mechanical seal.

- O-rings FPM.

- Higher or lower liquid or ambient temperatures.

- Flanges to screw, in chrome-nickel steel for MXV-E 25-32-40.

Designation

MXVL-E 25-2 05 G
MXVL-E 50-16 05 H1

Series _____
 AISI 316L Version (no code = AISI 304 version) _____
 Variable Speed _____
 DN ports in mm _____
 Rated capacity in m³/h (n = 2900 rpm) _____
 Number of stages _____

Construction variants

threaded ports _____ G
 flanged ports _____ F
 with support feet for horizontal installation H, variant 1 _____

Advantages

- Energy saving.
- Compact Design.
- Economical use of space.
- Flexible operation.
- Low-noise operation.
- Programmable to suit the system requirements.

Main features

- Control range 1500 to 2900 rpm.
- Dry-running protection.
- Phase failure protection.
- Overload protection.
- Low-noise: max 64 dB(A).

Modality of use

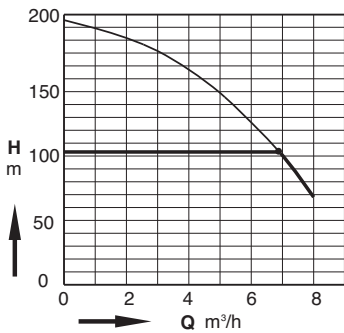

Constant pressure mode

With a pressure transducer the system maintains a constant pressure with variation of flow.

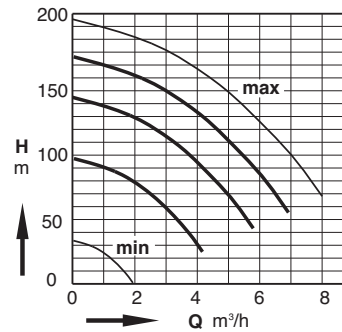

Fixed speed mode

Variation of the operating frequency allows for the choice of operating curve to match the system requirements

The system is factory programmed and can be easily modified via the local control panel (optional).

Coverage chart $n \approx 2900$ rpm

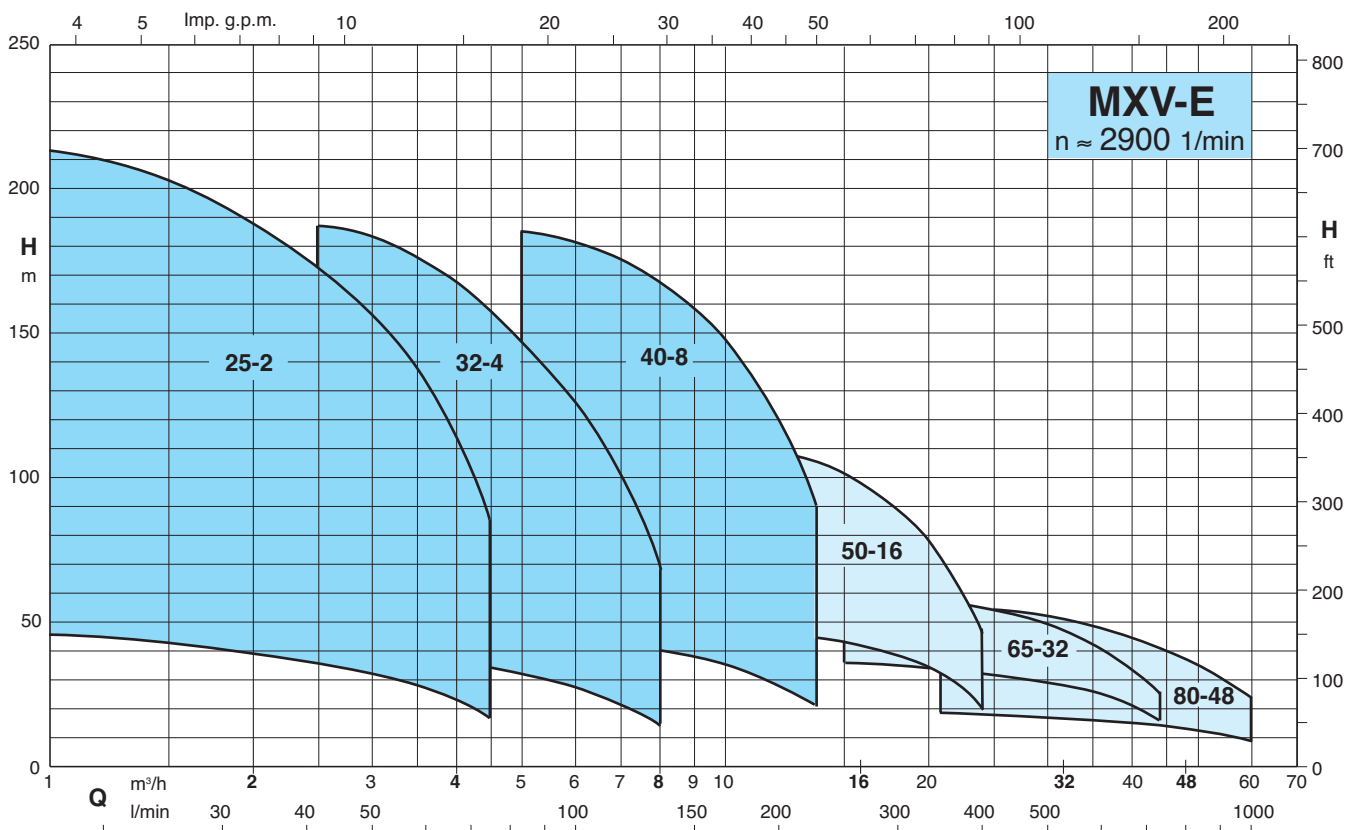

Characteristic curves and performance $n \approx 2900$ rpm

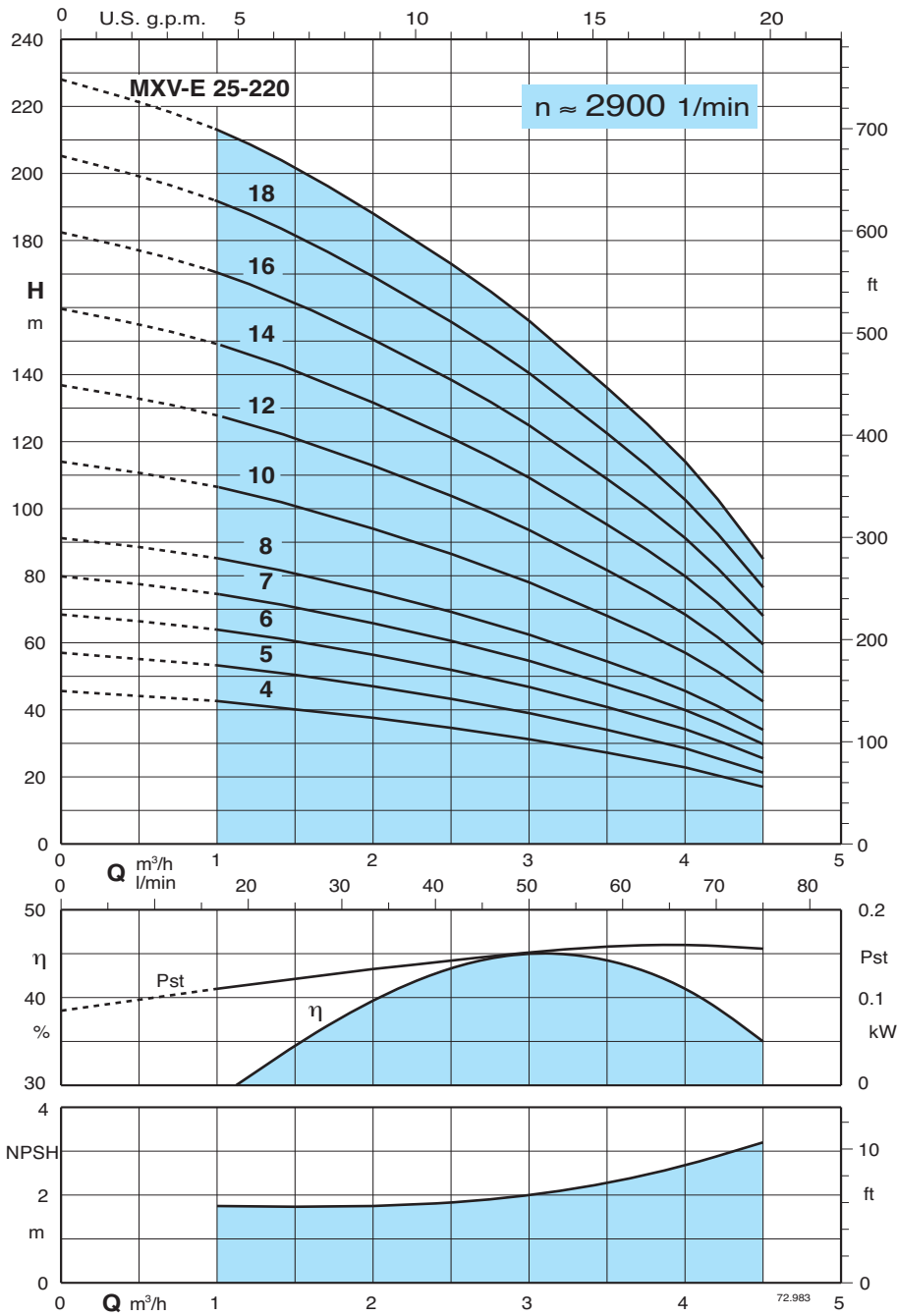

Test results with clean cold water, without gas content.

A safety margin of + 0.5 m is recommended for the NPSH value.

Tolerances in accordance with UNI EN ISO 9906:2012.

Head and power values valid for liquids with density $\rho = 1,0$ kg/dm³ and kinematic viscosity $\nu = \max 20$ mm²/sec.

Pst = Power with reference to one stage.

Pump type	P ₂		Q m ³ /h l/min	H (m)										
	kW	HP		0	1	1,5	2	2,5	3	3,5	4	4,5		
MXV-E 25 - 204	0,75	1	0	0	16,6	25	33,3	41,6	50	58,3	66,6	75		
MXV-E 25 - 205	1,1	1,5	44	42,5	40	37,5	34,5	31	27	22,5	17			
MXV-E 25 - 206	1,1	1,5	56	53	50	47	43	39	34	28	21			
MXV-E 25 - 207	1,5	2	68	63,5	60,5	56	51,5	46,5	40,5	34	25			
MXV-E 25 - 208	1,5	2	79,5	74	70,5	65,5	60	54,5	47,5	39,5	30			
MXV-E 25 - 210	2,2	3	91	85	80,5	75	69	62	54	45,5	34			
MXV-E 25 - 212	2,2	3	114	106	101	94	86	78	68	57	42			
MXV-E 25 - 214	3	4	136	127	121	112	103	93,5	81,5	68	51			
MXV-E 25 - 216	3	4	159	149	141	131	121	109	95	79,5	59			
MXV-E 25 - 218	3	4	182	170	161	150	138	124	108	91	68			
MXV-E 25 - 220	4	5,5	205	191	181	169	155	140	122	102	76			
			228	213	202	188	173	156	136	114	85			

Characteristic curves and performance $n \approx 2900$ rpm

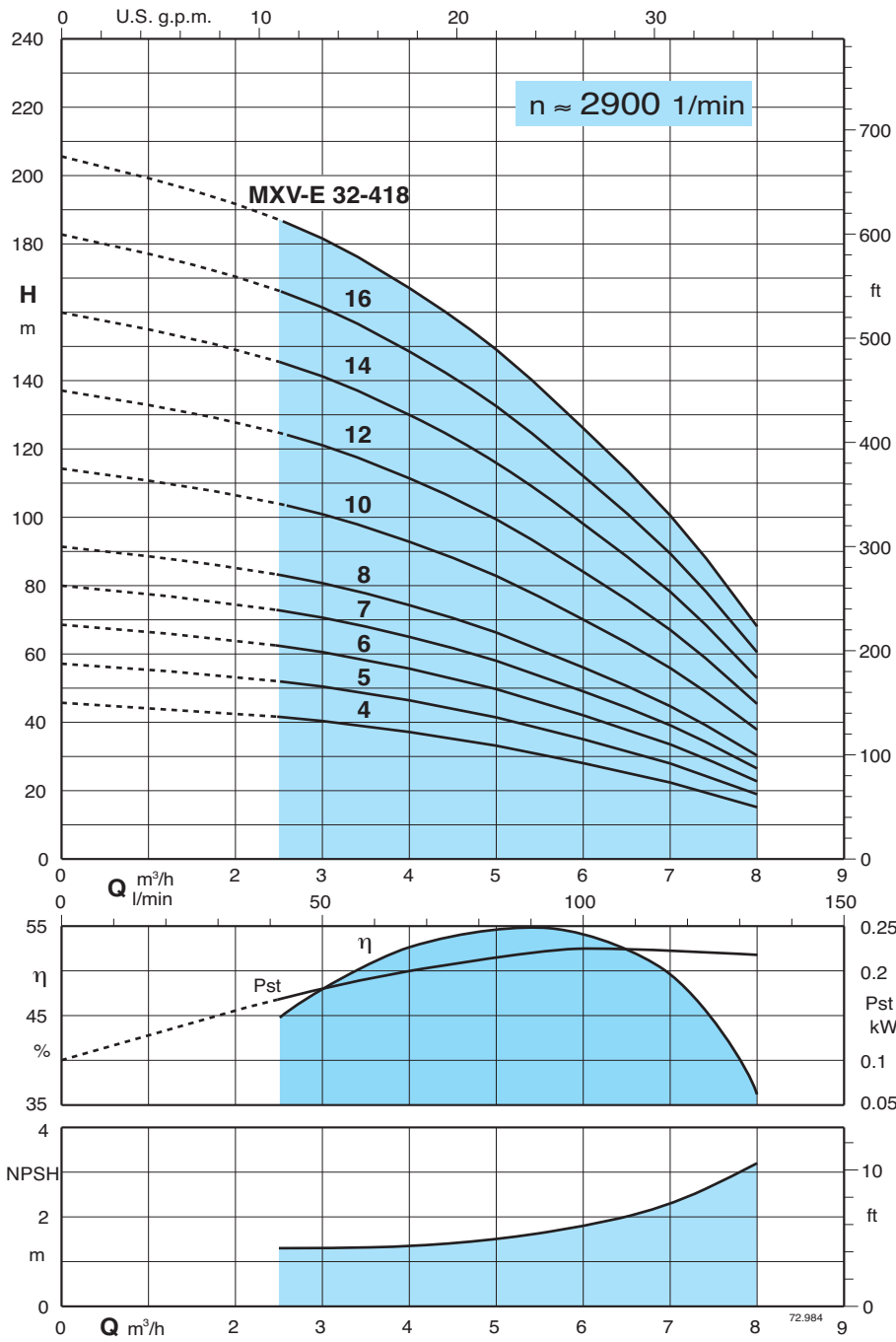

Test results with clean cold water, without gas content.

A safety margin of + 0.5 m is recommended for the NPSH value.

Tolerances in accordance with UNI EN ISO 9906:2012.

Head and power values valid for liquids with density $\rho = 1,0$ kg/dm³ and kinematic viscosity $\nu = \max 20$ mm²/sec.

P_{st} = Power with reference to one stage.

Pump type	P_2		Q m ³ /h l/min	0	2,5	3	3,5	4	4,5	5	6	7	8
	kW	HP		0	41,6	50	58,3	66,6	75	83,3	100	116,6	133,3
MXV-E 32 - 404	1,1	1,5	H m	45	41,5	40	38,5	36,5	34,5	32,5	27,5	22	14,5
MXV-E 32 - 405	1,5	2		56	51,5	50	48	46	43,5	41	34,5	27,5	18,5
MXV-E 32 - 406	1,5	2		68	62	60	58	55,5	52,5	49,5	42	33,5	22,5
MXV-E 32 - 407	2,2	3		79,5	72,5	70,5	68	65	61,5	58	49	39	26,5
MXV-E 32 - 408	2,2	3		91	83	80,5	78	74	70	66	56	44,5	30
MXV-E 32 - 410	3	4		114	104	101	97,5	93	88	83	70	56	38
MXV-E 32 - 412	3	4		136	124	121	117	111	105	99,5	84	67	45,5
MXV-E 32 - 414	4	5,5		159	145	141	136	130	123	116	98	78	53
MXV-E 32 - 416	4	5,5		182	166	161	156	148	140	132	112	89,5	60,5
MXV-E 32 - 418	5,5	7,5		205	187	181	175	167	158	149	126	100	68

Characteristic curves and performance $n \approx 2900$ rpm

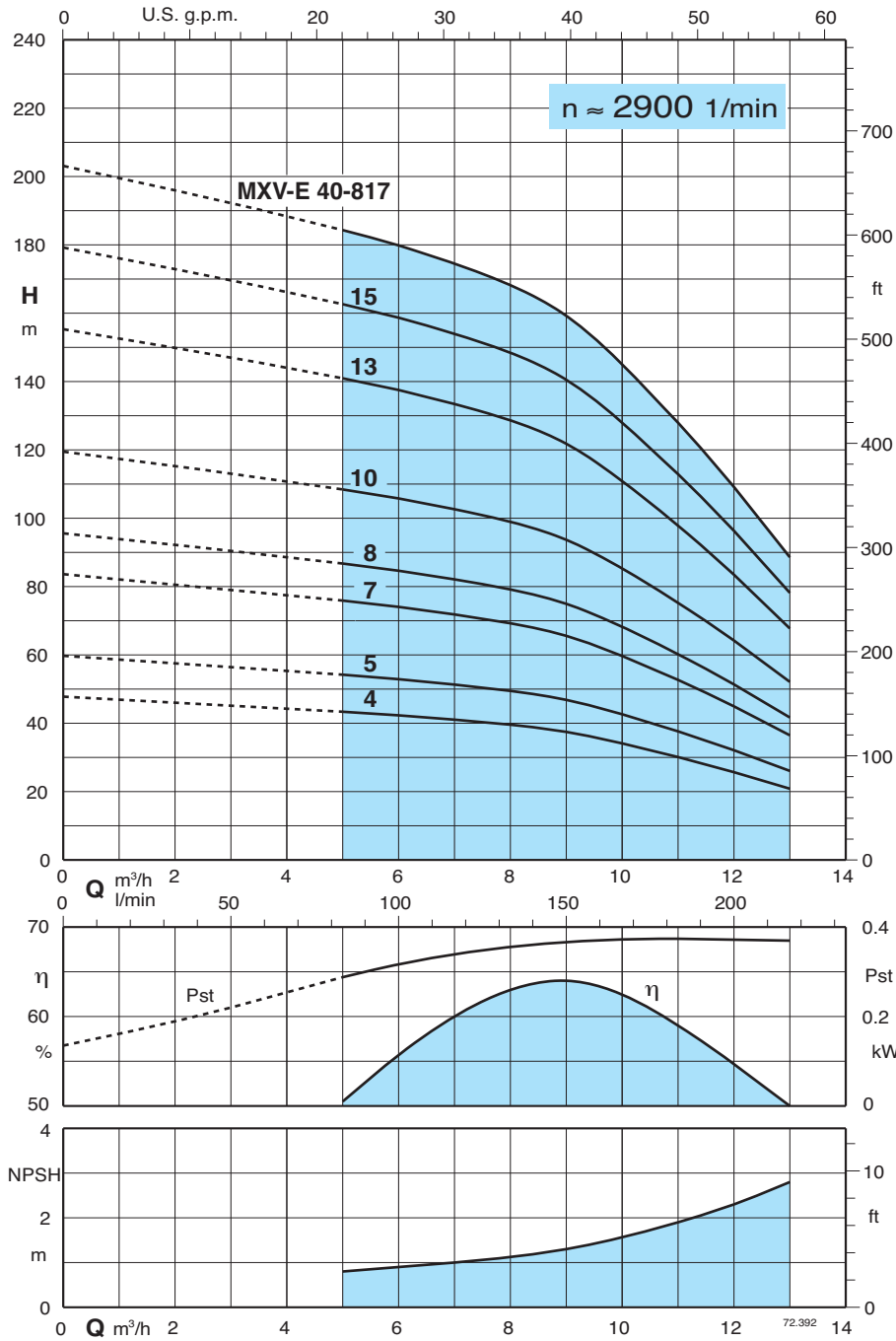

Test results with clean cold water, without gas content.

A safety margin of + 0.5 m is recommended for the NPSH value.

Tolerances in accordance with UNI EN ISO 9906:2012.

Head and power values valid for liquids with density $\rho = 1,0 \text{ kg/dm}^3$ and kinematic viscosity $\nu = \text{max } 20 \text{ mm}^2/\text{sec}$.

Pst = Power with reference to one stage.

Pump type	P2		Q m³/h l/min	H m											
	kW	HP		0	5	6	7	8	9	10	11	12	13		
MXV-E 40 - 804	2,2	3	0	0	83,3	100	116,6	133,3	150	166,6	183,3	200	216,6		
MXV-E 40 - 805	2,2	3	47	43	42	41	40	37	34	30	26	21			
MXV-E 40 - 807	3	4	59	54	53	51	50	47	43	38	32	26			
MXV-E 40 - 808	4	5,5	83	76	74	72	69	66	60	53	45	36			
MXV-E 40 - 810	5,5	7,5	95	87	85	82	79	75	69	60	51	42			
MXV-E 40 - 813	5,5	7,5	119	109	106	103	99	94	86	75	64	52			
MXV-E 40 - 815	7,5	10	155	141	138	134	129	122	111	98	84	68			
MXV-E 40 - 817	7,5	10	179	163	159	154	149	141	128	113	96	78			
			202	184	180	175	168	159	145	128	109	89			

Characteristic curves and performance $n \approx 2900$ rpm

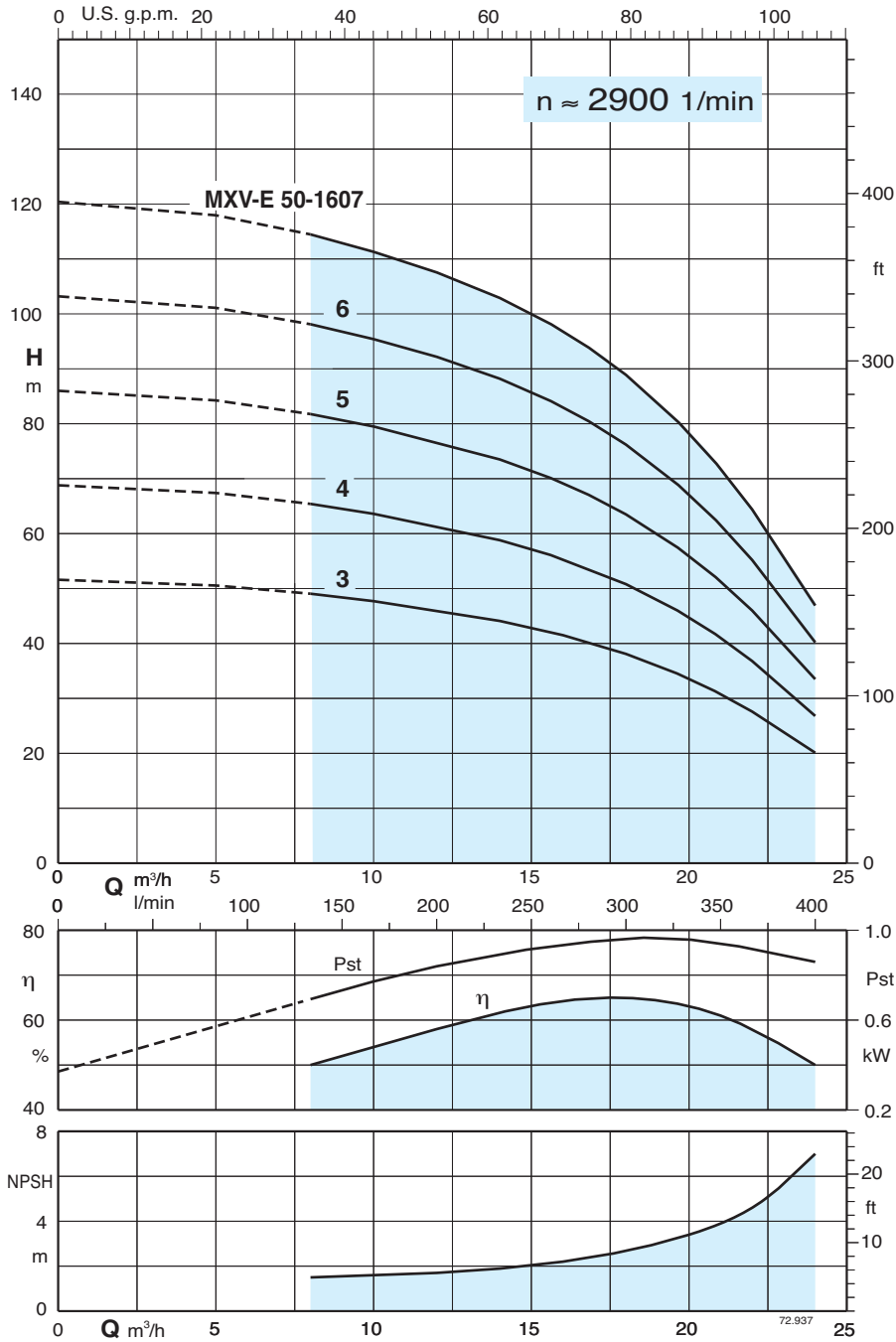

Test results with clean cold water, without gas content.

A safety margin of + 0.5 m is recommended for the NPSH value.

Tolerances in accordance with UNI EN ISO 9906:2012.

Head and power values valid for liquids with density $\rho = 1,0 \text{ kg/dm}^3$ and kinematic viscosity $\nu = \text{max } 20 \text{ mm}^2/\text{sec}$.

Pst = Power with reference to one stage.

Pump type	P ₂		Q m³/h l/min	0	8	10	12	14	16	18	20	22	24
	kW	HP		0	133,3	166,6	200	233	266	300	333	366	400
MXV-E 50 - 1603	4	5,5	H m	51	49	48	46	44	41	38	33	27	20
MXV-E 50 - 1604	5,5	7,5		69	65	63	61	59	55	51	44	37	27
MXV-E 50 - 1605	5,5	7,5		86	81	79	76	73	69	63	55	46	33
MXV-E 50 - 1606	7,5	10		103	98	95	92	88	83	76	67	55	40
MXV-E 50 - 1607	7,5	10		120	114	111	107	103	97	89	78	64	47

Characteristic curves and performance $n \approx 2900$ rpm

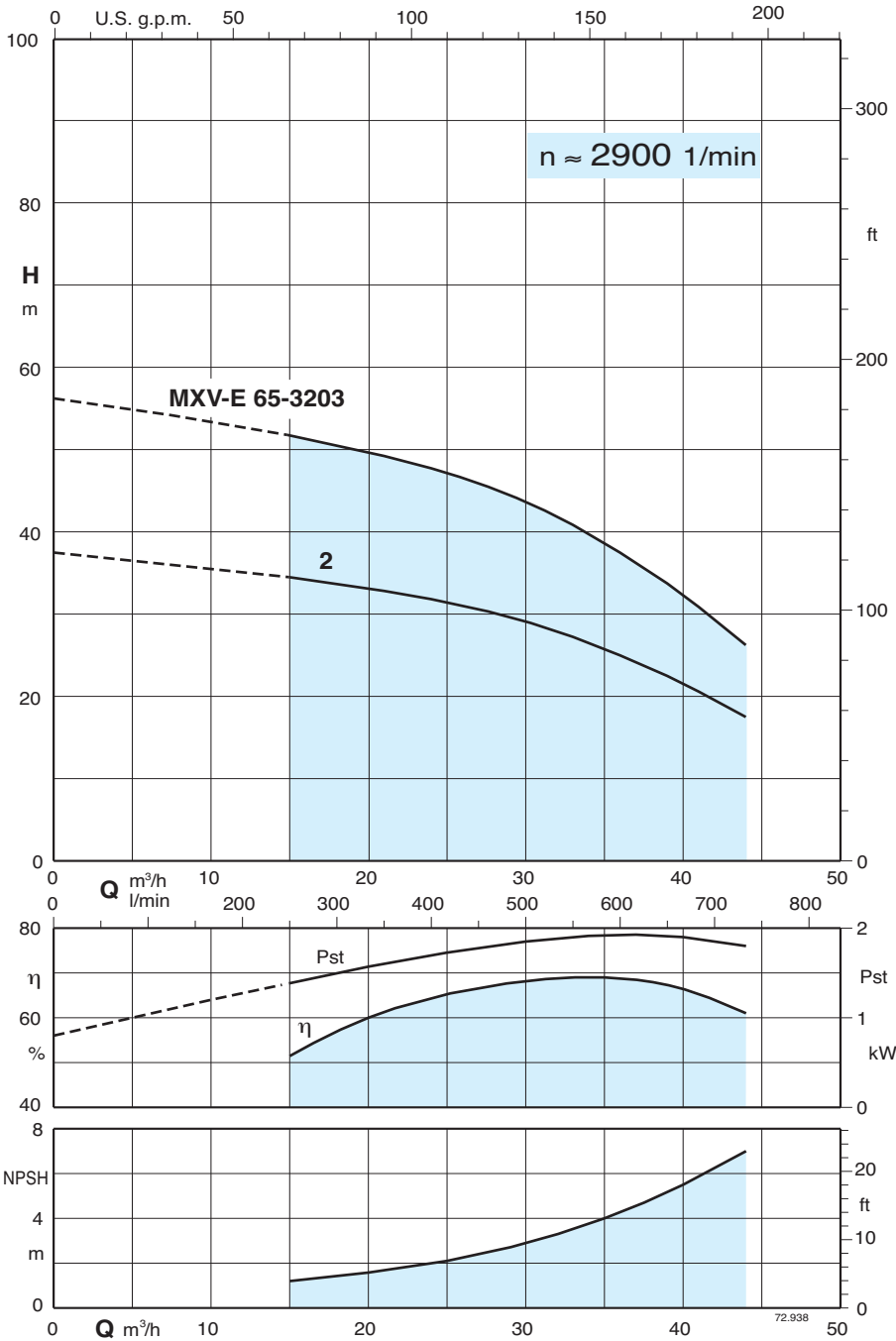

Test results with clean cold water, without gas content.

A safety margin of + 0.5 m is recommended for the NPSH value.

Tolerances in accordance with UNI EN ISO 9906:2012.

Head and power values valid for liquids with density $\rho = 1,0 \text{ kg/dm}^3$ and kinematic viscosity $\nu = \text{max } 20 \text{ mm}^2/\text{sec}$.

Pst = Power with reference to one stage.

Pump type	P2		Q m³/h l/min	0	15	21	24	27	30	33	36	39	44
	kW	HP		0	250	350	400	450	500	550	600	650	733
MXV-E 65 - 3202	4	5,5	H	37	34	32	31	30	29	27	24,5	22	17
MXV-E 65 - 3203	7,5	10	m	55,5	51	49	47,5	46	43,5	40,5	37	33,5	25,5

Characteristic curves and performance $n \approx 2900$ rpm

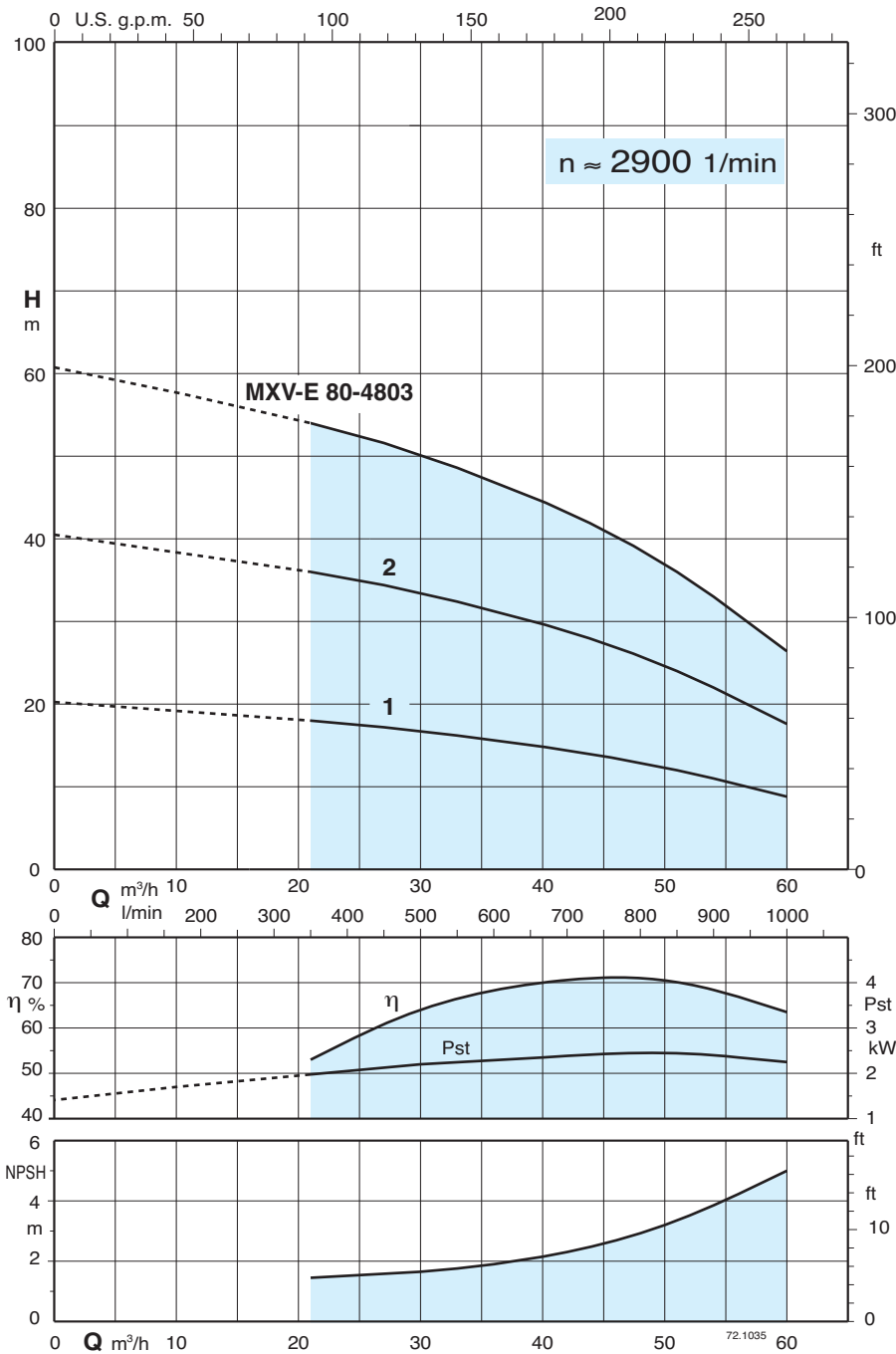

Test results with clean cold water, without gas content.

A safety margin of + 0.5 m is recommended for the NPSH value.

Tolerances in accordance with UNI EN ISO 9906:2012.

Head and power values valid for liquids with density $\rho = 1,0$ kg/dm³ and kinematic viscosity $\nu = \max 20$ mm²/sec.

Pst = Power with reference to one stage.

Pump type	P ₂		Q m ³ /h l/min	0	21	27	33	39	45	48	51	54	60
	kW	HP		0	350	450	550	650	750	800	850	900	1000
MXV-E 80 - 4801	3	4	H m	20	18	17	16	15	13	12	10,7	9,5	7
MXV-E 80 - 4802	5,5	7,5		40,5	36	34,5	32,5	29,5	26,5	24,5	22	20	15,5
MXV-E 80 - 4803	7,5	10		61	54	51	48	44	40	37	34	31	24,5

Dimensions and weights

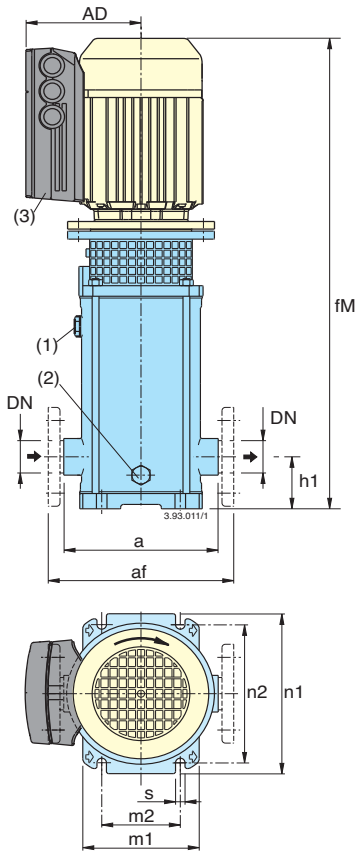

Pump	Motor		MXV-E (G) threaded ports		MXV-E (F) flanged ports		mm					Net weight kg			
	kW	HP	G ISO 228	a	DN	af	h1	fm	AD	n1	n2		m1	m2	s
MXV-E 25-204	0,75	1						627	149						31
MXV-E 25-205	1,1	1,5					675	153							38
MXV-E 25-206	1,1	1,5					699	153							39
MXV-E 25-207	1,5	2					723	153							43
MXV-E 25-208	1,5	2					747	153							44
MXV-E 25-210	2,2	3	G1	215	25	250	75	812	169	210	180	150	100	12,5	53
MXV-E 25-212	2,2	3					860	169							54
MXV-E 25-214	3	4					908	169							56
MXV-E 25-216	3	4					956	169							57
MXV-E 25-218	3	4					1004	169							59
MXV-E 25-220	4	5,5					1052	184							69
MXV-E 32-404	1,1	1,5					651	153							38
MXV-E 32-405	1,5	2					675	153							39
MXV-E 32-406	1,5	2					699	153							42
MXV-E 32-407	2,2	3					740	169							50
MXV-E 32-408	2,2	3					764	169							51
MXV-E 32-410	3	4	G1 1/4	215	32	250	75	812	169	210	180	150	100	12,5	54
MXV-E 32-412	3	4					860	169							55
MXV-E 32-414	4	5,5					908	186							66
MXV-E 32-416	4	5,5					1000	186							67
MXV-E 32-418	5,5	7,5					1133	212							87
MXV-E 40-804	2,2	3					697	169							48
MXV-E 40-805	2,2	3					727	169							49
MXV-E 40-807	3	4					787	169							53
MXV-E 40-808	4	5,5					861	186							64
MXV-E 40-810	5,5	7,5	G1 1/2	225	40	280	80	1026	186	246	215	190	130	14	89
MXV-E 40-813	5,5	7,5					1116	212							91
MXV-E 40-815	7,5	10					1176	212							98
MXV-E 40-817	7,5	10					1236	212							99

(1) Filling (2) Draining (3) Standard position of terminal box. (for other positions rotate motor through 90° or 180°)

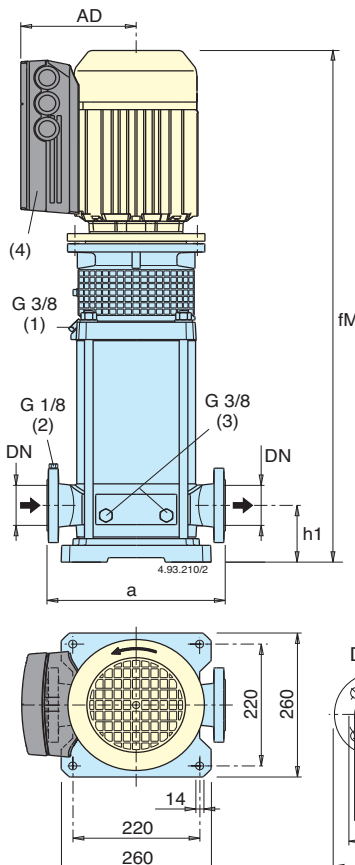

Pump	Motor		mm					Net weight kg
	kW	HP	DN	a	h1	fm	AD	
MXV-E 50-1603	4	5,5				730	186	79
MXV-E 50-1604	5,5	7,5				824	212	80
MXV-E 50-1605	5,5	7,5	50	300	90	858	212	105
MXV-E 50-1606	7,5	10				893	212	112
MXV-E 50-1607	7,5	10				927	212	113
MXV-E 65-3202	4	5,5				741	186	82
MXV-E 65-3203	7,5	10	65	320	105	847	212	113
MXV-E 80-4801	3	4				745	186	73
MXV-E 80-4802	5,5	7,5	80	320	105	840	212	107
MXV-E 80-4803	7,5	10				901	212	115

(1) Filling and air vent (2) Sfiato aspirazione (3) Draining (4) Standard position of terminal box. (for other positions rotate motor through 90° or 180°)

Flanges EN 1092-2 PN 25 - 40

Holes					
DN	DE	DK	DG	N.	Ø
50	165	125	99	4	19
65	185	145	118	8	19
80	200	160	132	8	19

Features

MXV-E pump series with on-board Danfoss® frequency controller. The **MXV-E** series is available with motors up to 7.5 kW, connected directly to the **MXV** series of vertical, in-line multi-stage pumps (see the Calpeda general catalogue for more information). For units over 7.5 kW we offer panel mounted control systems.



Motor with factory programmed integrated frequency controller, series **VLT FCM 300**.



Programmable Local Control Panel with alphanumeric display.



Service plug with cable kit for a simple connection to the Local Control Panel.

The frequency converters feature a RS 485 connection.

Provision to connect a potentiometer to regulate the set point.

