



Construction

Vertical multi-stage pumps with suction and delivery connections of the same diameter and arranged along the same axis (in-line). Corrosion-resistant bearing sleeves lubricated by the pumped liquid. A pump with thrust bearing and sleeve coupling for use of any standard motor with IM V1 construction.

Applications

For water supply systems.
For clean non-explosive liquids, without solid, filamentary or abrasive matter (with adaptation of sealing materials on request). A universal pump for civil and industrial use, for pressure-boosting systems, fire-extinguishing systems, high-pressure washing plants, irrigation, agricultural uses and sport installations.

Operating conditions

Temperature of liquid: from -15 °C to +110 °C.
Operating environment temperature: up to 40 °C.
Maximum permissible pressure in pump casing: 25 bar.

Motor

Standard-type: 2-4 pole induction motor, 60 Hz.
Motor suitable for operation with frequency converter.
Classification scheme IE2 for three-phase motors from 0,75 kW.
Construction IM V1.
Insulation class F.
Protection IP 55.
three-phase with rated voltage: up to 3 kW 220/380 V (IEC 38);
from 4 kW 380/660 V (IEC 38).
Rated speed of rotation (60 Hz): **MXV** = 3450 rpm
MXV4 = 1750 rpm.

MXV 25-2, 32-4, 40-8

All parts that come into contact with the liquid, including wet-end covers, are in chrome-nickel stainless steel AISI 304.

Materials (wetted parts)

Component	Material
Flange External jacket Suction casing Delivery casing Stage casing Impeller Lower cover Upper cover Spacer sleeve	Chrome-nickel steel 1.4301 EN 10088 (AISI 304)
Pump shaft Plug	Chrome-nickel steel 1.4305 EN 10088 (AISI 303)
Bearing sleeve Bearing in stage casing	Corrosion-resistant, cemented carbide Ceramic alumina
Mechanical seal ISO 3069 - KU	Hard metal/Carbon/EPDM.
Wear ring	PTFE
O-rings	NBR

Direction of rotation: clockwise as seen from the motor.

Variants (to be specified when ordering)

Pump with threaded ports (G).
Pump with flanged ports (F).
Pump without motor.
Pump with standard motor.

Other variants (on request)

With counter-flanges in chrome-nickel steel.
O-rings FPM.
Other mechanical seal.
Pump with motor of Client's choice (if available).
Single-phase motor 220 V, up to 2.2 kW.
Other voltage ratings.
Higher or lower liquid or ambient temperatures.

MXV 50-16, 65-32, 80-48

Internal parts in contact with the liquid in chrome-nickel stainless steel, AISI 304 with pump casing and upper cover in cast iron.

Materials (wetted parts)

Component	Material
Pump casing Upper cover	Cast iron GJL 250 EN 1561
External jacket Stage casing Impeller Spacer sleeve	Chrome-nickel steel 1.4301 EN 10088 (AISI 304)
Pump shaft Plug	Chrome-nickel steel 1.4305 EN 10088 (AISI 303)
Bearing sleeve Bearing in stage casing	Corrosion-resistant, cemented carbide Ceramic alumina
Mechanical seal ISO 3069 - KU	Hard metal/Carbon/EPDM
Wear ring	PTFE
O-rings	NBR

Direction of rotation: anticlockwise as seen from the motor.

Variants (to be specified when ordering)

Pump without motor.
Pump with standard motor.

Other variants (on request)

O-rings FPM.
Other mechanical seal.
Pump with motor of Client's choice (if available).
Other voltage ratings.
Pump with support feet for horizontal installation (H1 or H2).
Support feet for horizontal installation, set.
Welding counter-flanges, PN 25 (steel).
Higher or lower liquid or ambient temperatures.

MXV 25-2, 32-4, 40-8

Designation

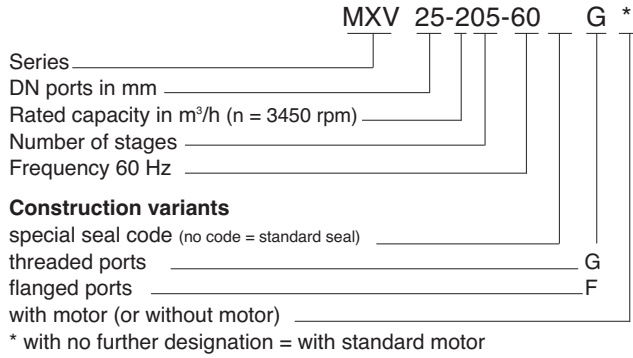

MXV 50-16, 65-32, 80-48

Designation

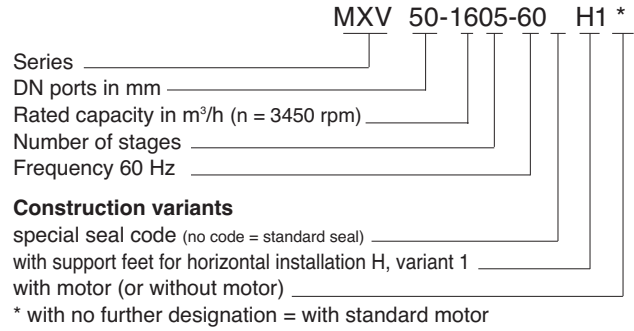

Pipe connection

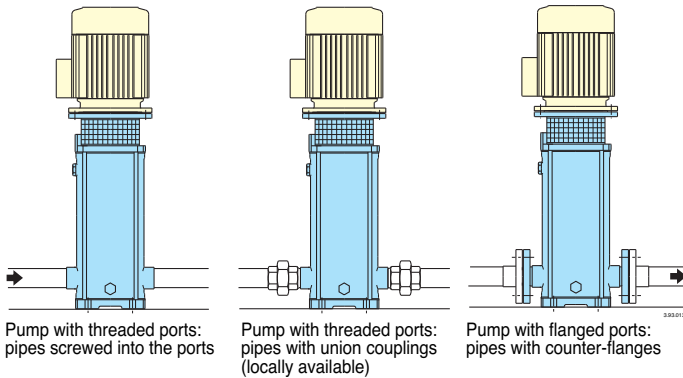

Installations

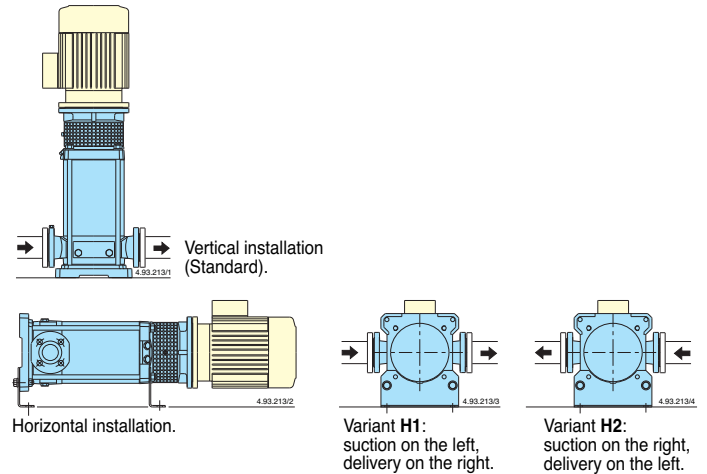

Variable parts

Pump size MXV - MXV4			Number of stages	Stage casings with bearing
25 - 203	32 - 403	40 - 803	3	1
25 - 204	32 - 404	40 - 804	4	1
25 - 205	32 - 405	40 - 805	5	1
25 - 206	32 - 406	40 - 806	6	1
25 - 207	32 - 407	40 - 807	7	1
25 - 208	32 - 408	40 - 808	8	1
25 - 210	32 - 410	40 - 810	10	1
25 - 212	32 - 412	40 - 811	11	2
		40 - 813	12	2
		40 - 815	13	2
25 - 214	32 - 414	40 - 815	14	2
			15	2
25 - 216	32 - 416		16	2
25 - 218	32 - 418		18	2
25 - 220		40 - 817	17	3
		40 - 819	19	3
			20	3

Variable parts

Pump size MXV - MXV4			Number of stages	Stage casings with bearing
50 - 1603 50 - 1604 50 - 1605 50 - 1606 50 - 1607 50 - 1608 50 - 1609 50 - 1610	65 - 3202	80 - 4801	1	1
	65 - 3203	80 - 4802	2	1
	65 - 3204	80 - 4803	3	1
	65 - 3205	80 - 4804	4	1
	65 - 3206	80 - 4805	5	1
	65 - 3207		6	1
			7	1
			8	1
			9	1
			10	1
50 - 1611 50 - 1612 50 - 1614 50 - 1616	65 - 3208 65 - 3209 65 - 3210	80 - 4806	6	2
		80 - 4807	7	2
		80 - 4808	8	2
			9	2
			10	2
			11	2
	65 - 3212		12	2
			14	2
			16	2

Coverage chart

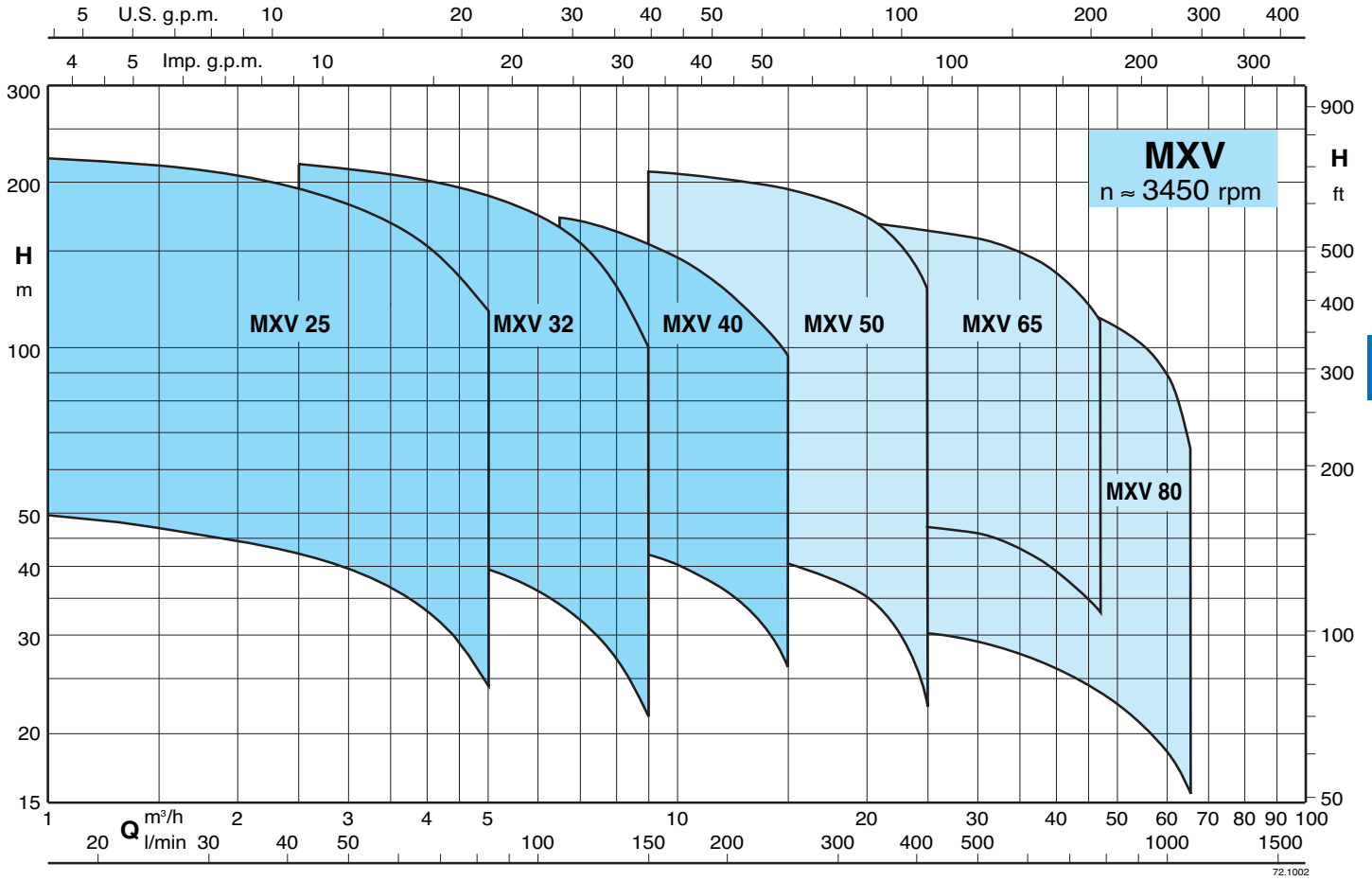

11

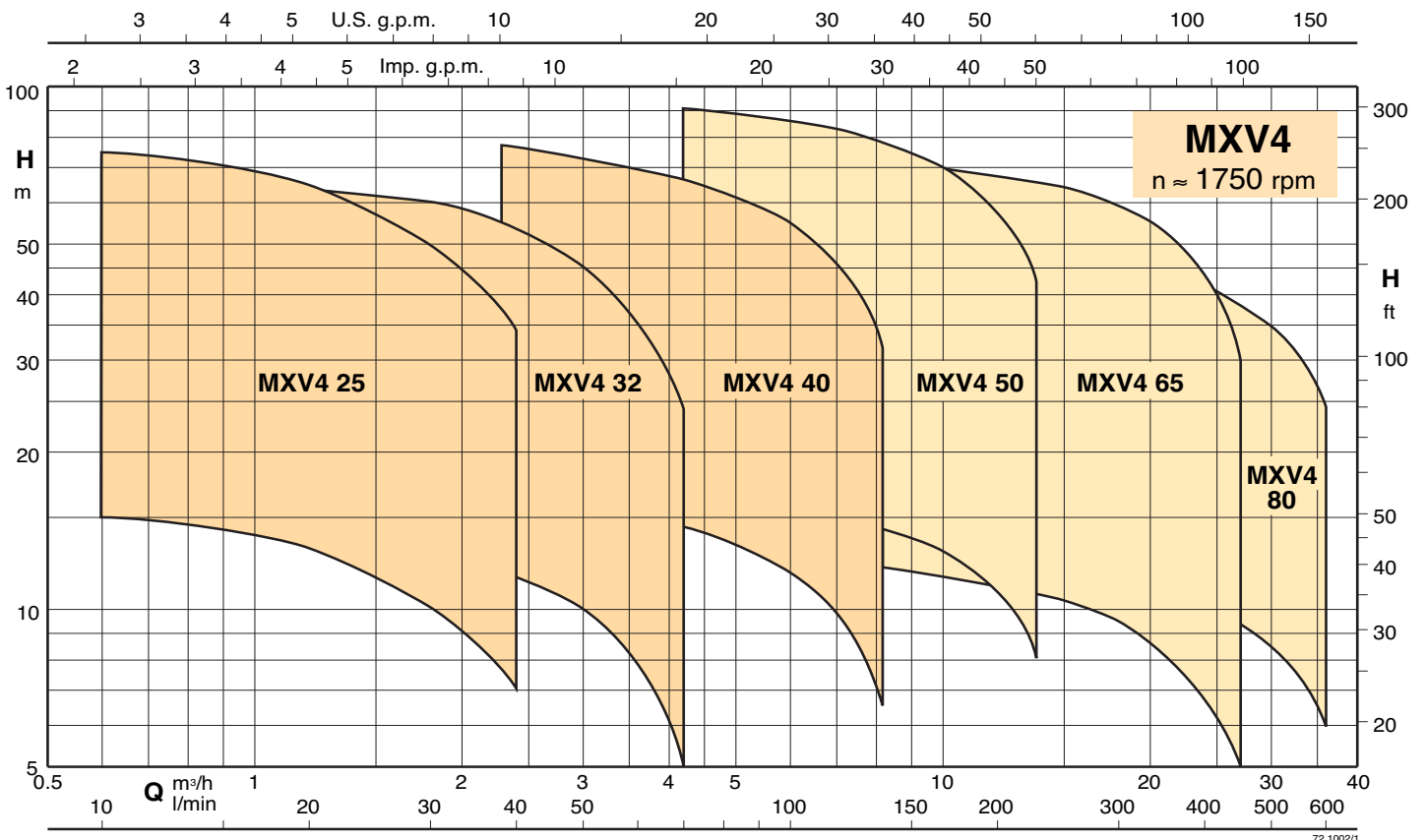

Characteristic curves n ≈ 3450 rpm

Dimensions and weights

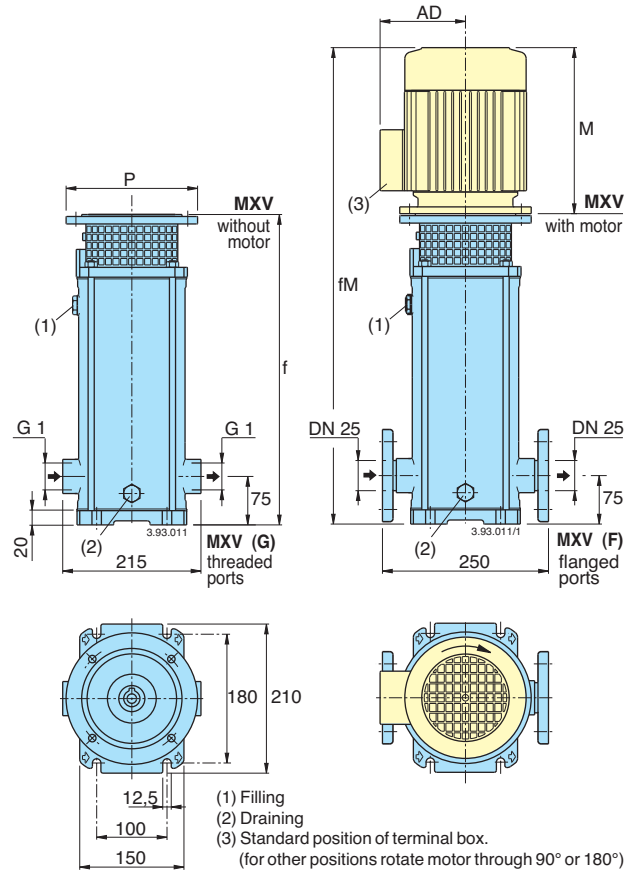
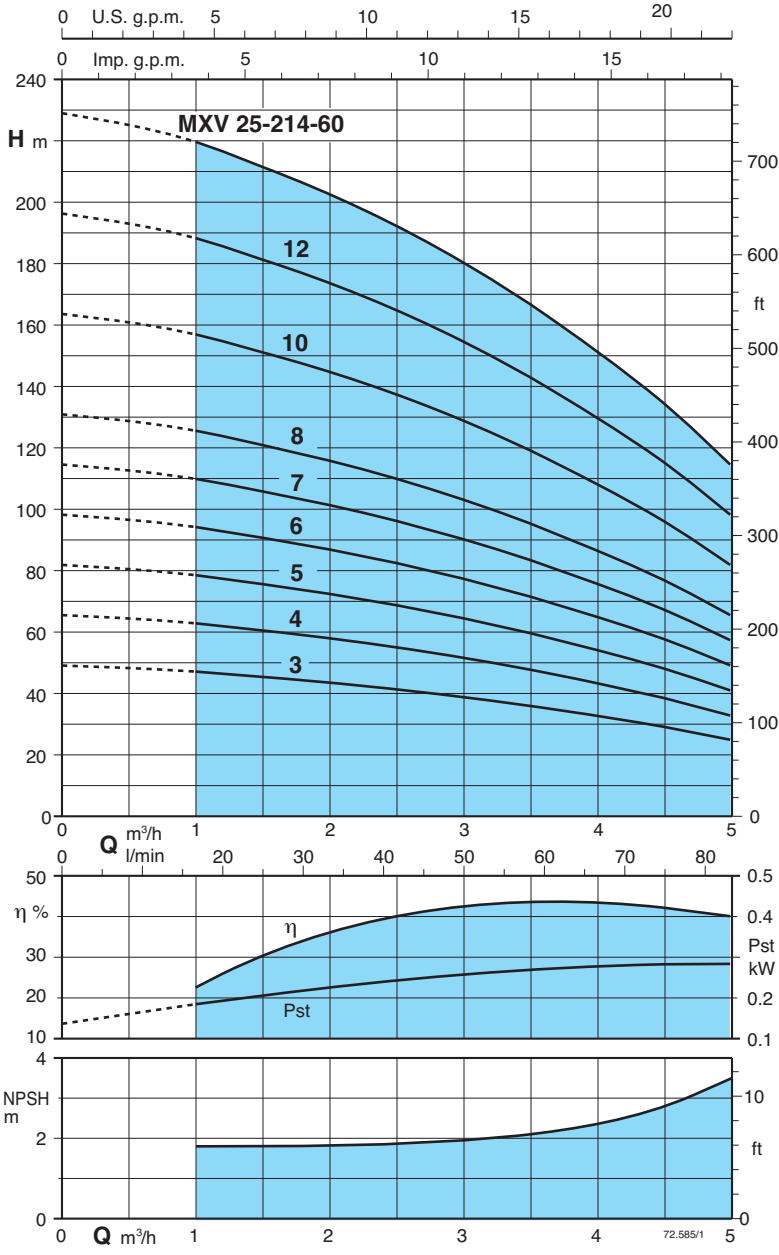

Counterflanges
in stainless steel

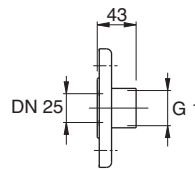

Flanges EN 1092-2
PN 25-40

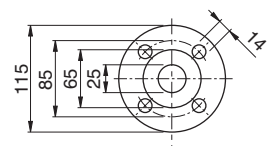

- (4) With standard motor
- (5) Weight MXV (G) = weight MXV (F) - 1 kg
- (6) Net weight pump with standard motor

Performance

Pump type	Motor power		Motor size	Q										
	kW	HP		m³/h	0	1	1,5	2	2,5	3	3,5	4	4,5	5
MXV 25-203-60/C	1,1	1,5	M80V1	l/min	0	16,6	25	33,3	41,6	50	58,3	66,6	75	83,3
MXV 25-204-60/C	1,1	1,5	M80V1	H m	49	47	45,3	43,4	41	38,6	35,7	32,4	28,7	24,5
MXV 25-205-60/C	1,5	2	M90V1		65	62	60,3	57,8	54,9	51,5	47,6	43,2	38,4	33
MXV 25-206-60/C	2,2	3	M90V1		81,5	78	75,4	72,3	68,6	64,4	59,5	54	48	41
MXV 25-207-60/C	2,2	3	M90V1		98	94	90,5	86,7	82,3	77,2	71,4	64,8	57,6	49
MXV 25-208-60/C	3	4	M100V1		114	110	105,6	101,2	96	90,1	83,3	75,5	67	57
MXV 25-210-60/C	3	4	M100V1		131	125	120,6	115,6	109,8	103	95,2	86,4	76,8	65
MXV 25-212-60/C	4	5,5	M112V1		163	156	150,8	144,5	137,2	128,7	119	108	96	82
MXV 25-214-60/C	4	5,5	M112V1		196	188	181	173,4	164,6	154,4	142,8	129,6	115,2	98
					229	219	211	202	192	180	167	151	134	114

Dimensions mm					Pump weight	
f	M (4)	fM	P	AD (4)	without motor (5)	with motor (6)
372	255	627	200	127,5	19	32,3
372	255	627	200	127,5	19	32,3
406	255	661	200	127,5	21	36,2
430	295	725	200	127,5	22	40,1
454	295	749	200	127,5	23	41,1
488	311	799	250	137,5	25	50,6
536	311	847	250	137,5	26	51,6
584	311	895	250	137,5	28	55,8
632	311	943	250	137,5	29	56,8

Head and power values valid for liquids with density $\rho = 1.0 \text{ kg/dm}^3$ and kinematic viscosity $\nu = \text{max } 20 \text{ mm}^2/\text{sec}$.
Pst = Power with reference to one stage.

Test results with clean cold water, without gas content.
A safety margin of + 0.5 m is recommended for the NPSH value.
Tolerances in accordance with ISO 9906, Annex A.

Characteristic curves n ≈ 3450 rpm

Dimensions and weights

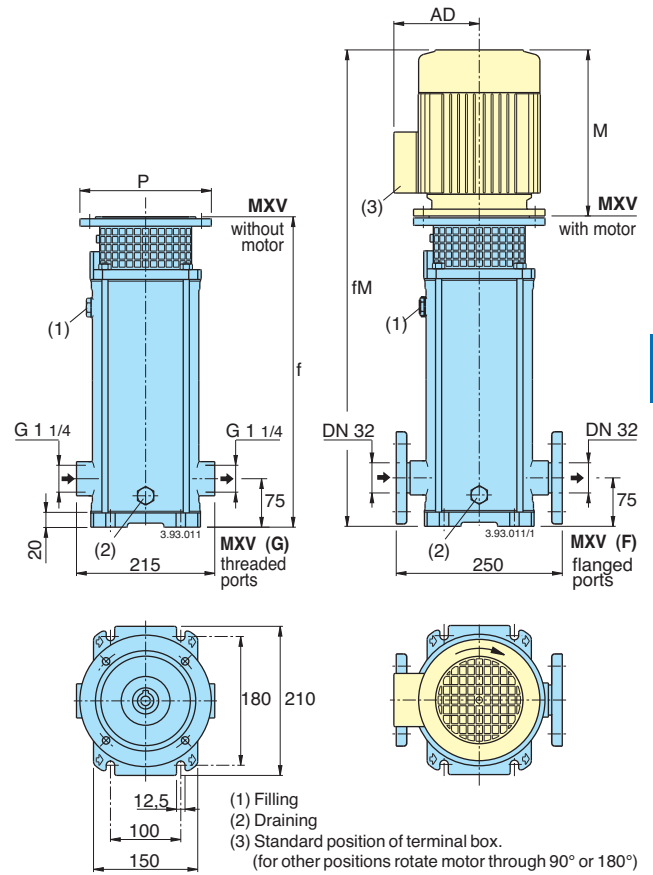
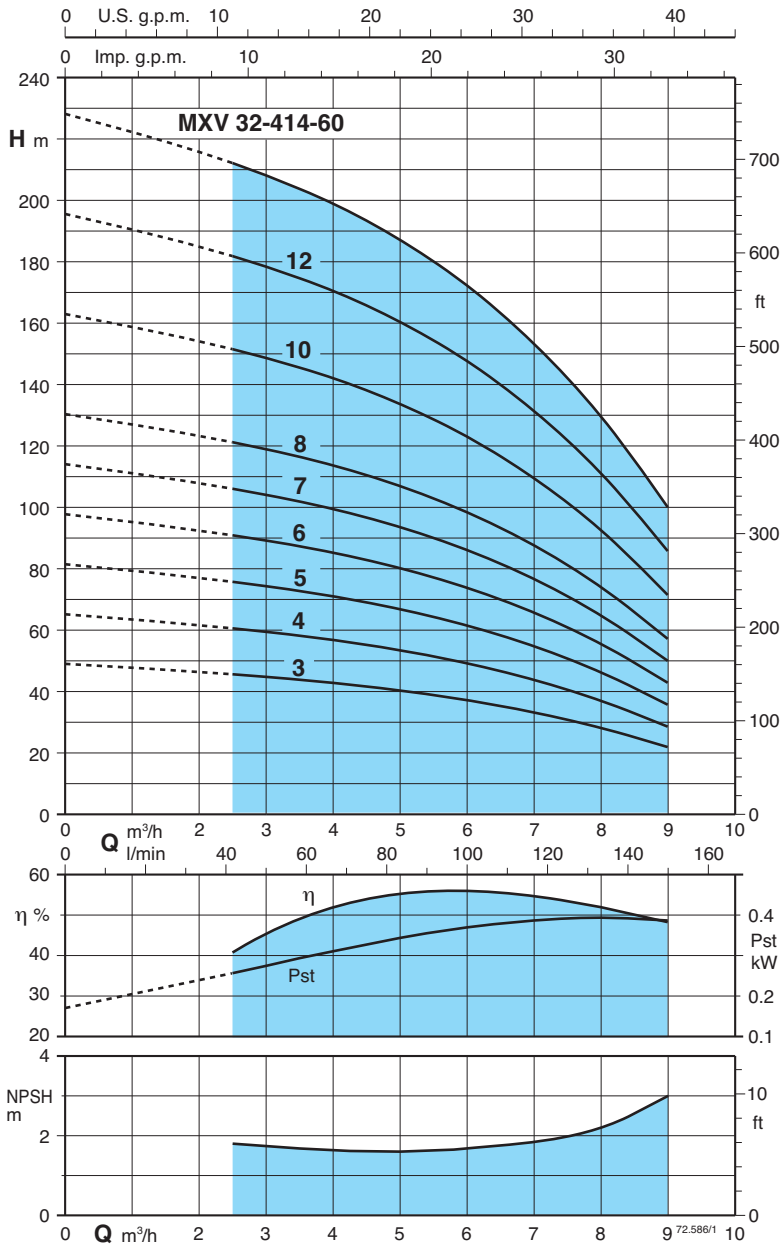

Counterflanges
in stainless steel

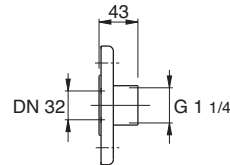

Flanges EN 1092-2
PN 25-40

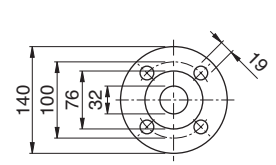

- (4) With standard motor
- (5) Weight MXV (G) = weight MXV (F) - 1kg
- (6) Net weight pump with standard motor

Performance

Pump type	Motor power		Motor size	Q m³/h l/min	H m										Dimensions mm					Pump weight without motor kg (5)	with motor kg (6)
	kW	HP			0	2,5	3	3,5	4	5	6	7	8	9	f	M (4)	fM	P	AD (4)		
MXV 32-403-60/C	1,5	2,2	M90V1	0	41,6	50	58,3	66,6	83,3	100	116,6	133,3	150	382	255	637	200	127,5	21	36,2	
MXV 32-404-60/C	2,2	3	M90V1	0	65	61	60	58,2	56,8	53,4	49,2	43,8	37	382	295	677	200	127,5	21	39,1	
MXV 32-405-60/C	2,2	3	M90V1	0	82	76	74,3	72,7	71	66,8	61,5	54,7	46,3	406	295	701	200	127,5	22	40,1	
MXV 32-406-60/C	3	4	M100V1	0	97	91	89,1	87,3	85,2	80,1	73,8	65,7	55,5	440	311	751	250	137,5	25	50,6	
MXV 32-407-60/C	3	4	M100V1	0	114	106	104	101,8	99,4	93,5	86,1	76,6	64,8	464	311	775	250	137,5	26	51,6	
MXV 32-408-60/C	4	5,5	M112V1	0	130	121	118,9	116,3	113,6	106,9	98,4	87,5	74,1	488	311	799	250	137,5	27	54,8	
MXV 32-410-60/C	4	5,5	M112V1	0	163	151	148,6	145,4	142	133,6	123	109,4	92,6	536	311	847	250	137,5	28	55,8	
MXV 32-412-60/C	5,5	7,5	M132V1	0	195	181	178,3	174,5	170,4	160,3	147,6	131,3	111,1	604	339	943	300	137,5	32	74,3	
MXV 32-414-60/C	5,5	7,5	M132V1	0	228	212	208	203,6	198,8	187	172,2	153,2	129,6	652	339	991	300	137,5	34	76,3	

Head and power values valid for liquids with density $\rho = 1.0 \text{ kg/dm}^3$ and kinematic viscosity $\nu = \text{max } 20 \text{ mm}^2/\text{sec}$.
Pst = Power with reference to one stage.

Test results with clean cold water, without gas content.
A safety margin of + 0.5 m is recommended for the NPSH value.
Tolerances in accordance with ISO 9906, Annex A.

Characteristic curves $n \approx 3450$ rpm

Dimensions and weights

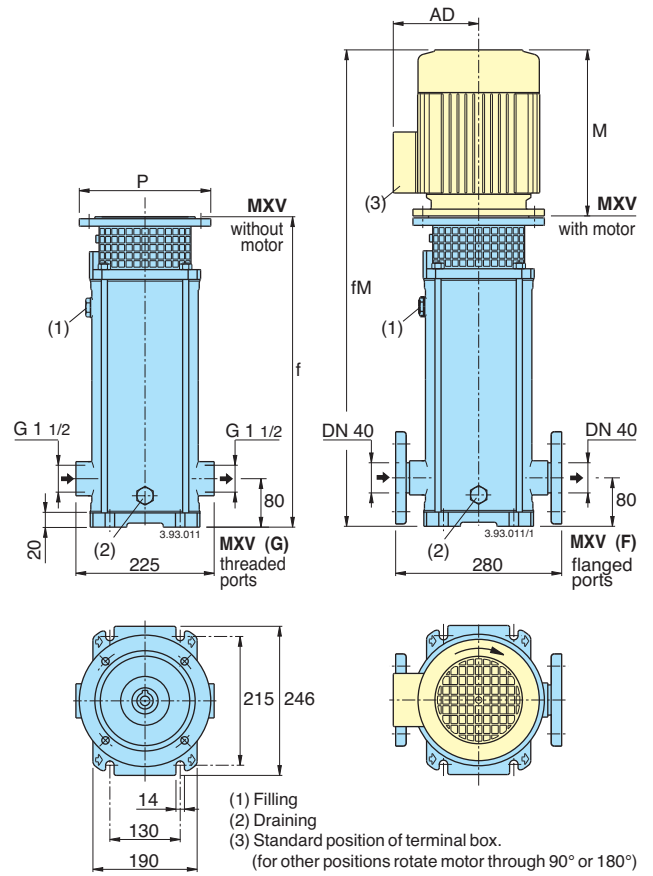
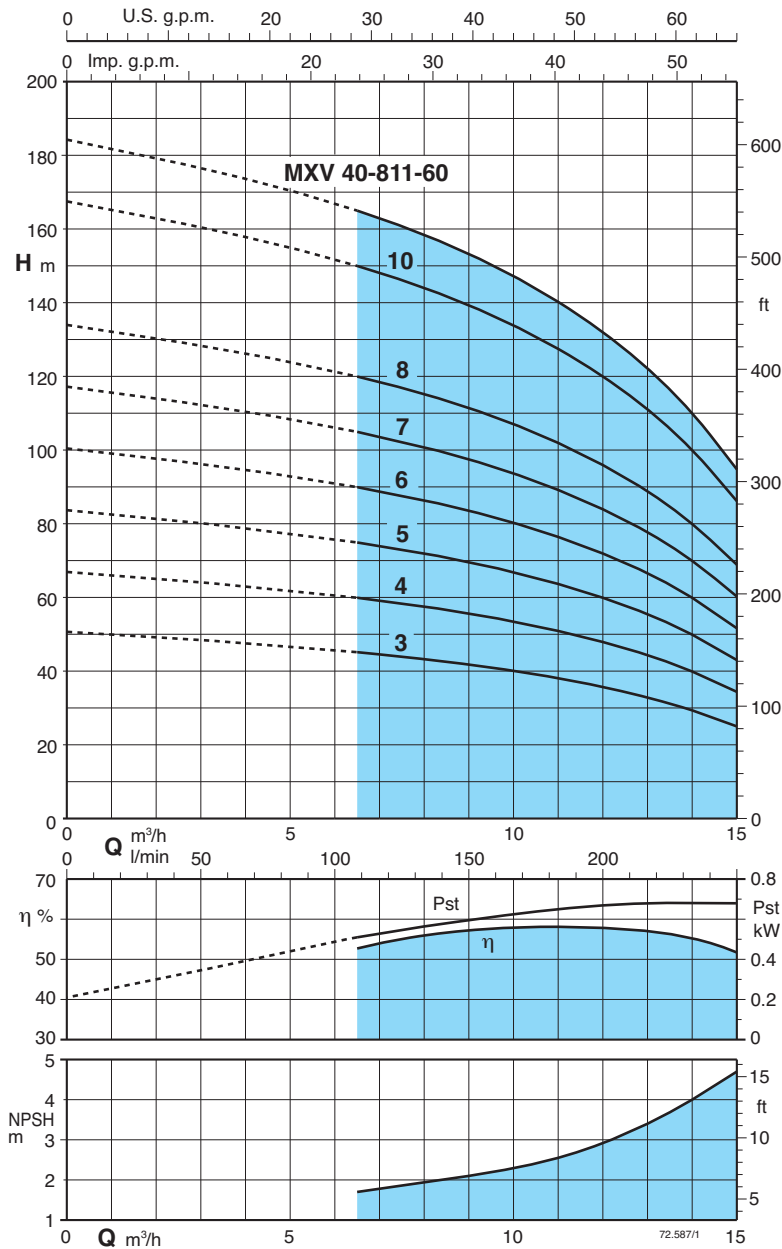

Counterflanges in stainless steel

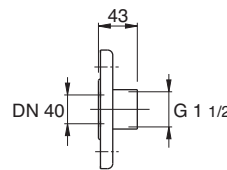

Flanges EN 1092-2 PN 25-40

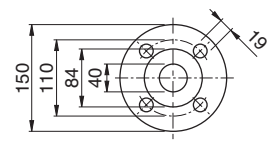

- (4) With standard motor
- (5) Weight MXV (G) = weight MXV (F) - 1kg
- (6) Net weight pump with standard motor

Performance

Pump type	Motor power		Motor size	Q m³/h l/min	H m																			
	kW	HP			0	6,5	8	9	10	11	12	13	14	15										
MXV 40-803-60/C	2,2	3	M90V1	0	108,3	133,3	150	166,6	183,3	200	216,6	233,3	250	50,4	45	43,5	42	40	38	36	33,3	30	25,8	
MXV 40-804-60/C	3	4	M100V1	0	67	60	58	56	53,5	51	48	44,5	40	34,5	67	60	58	56	53,5	51	48	44,5	40	34,5
MXV 40-805-60/C	4	5,5	M112V1	0	84	75	72,5	70	67	63,5	60	55,5	50	43	84	75	72,5	70	67	63,5	60	55,5	50	43
MXV 40-806-60/C	4	5,5	M112V1	0	101	90	87	84	80	76,5	72	66,5	60	51,5	101	90	87	84	80	76,5	72	66,5	60	51,5
MXV 40-807-60/C	5,5	7,5	M132V1	0	118	105	101	98	94	89	84	77,5	70	60	118	105	101	98	94	89	84	77,5	70	60
MXV 40-808-60/C	5,5	7,5	M132V1	0	134	120	116	112	107	102	96	89	80	69	134	120	116	112	107	102	96	89	80	69
MXV 40-810-60/C	7,5	10	M132V1	0	168	150	145	140	134	127	120	111	100	86	168	150	145	140	134	127	120	111	100	86
MXV 40-811-60/C	7,5	10	M132V1	0	185	165	159	154	147	140	132	122	110	94,5	185	165	159	154	147	140	132	122	110	94,5

Dimensions mm					Pump weight	
f	M (4)	fM	P	AD (4)	without motor kg (5)	with motor kg (6)
421	295	716	200	127,5	25	43,1
421	311	732	250	137,5	25	50,6
451	311	762	250	137,5	26	53,8
481	311	792	250	137,5	27	54,8
531	339	870	300	159,5	30	72,3
561	339	900	300	159,5	31	73,3
621	339	960	300	159,5	33	80,7
651	339	990	300	159,5	34	81,7

Head and power values valid for liquids with density $\rho = 1.0 \text{ kg/dm}^3$ and kinematic viscosity $\nu = \text{max } 20 \text{ mm}^2/\text{sec}$.
Pst = Power with reference to one stage.

Test results with clean cold water, without gas content.
A safety margin of + 0.5 m is recommended for the NPSH value.
Tolerances in accordance with ISO 9906, Annex A.

Characteristic curves n ≈ 3450 rpm

Dimensions and weights

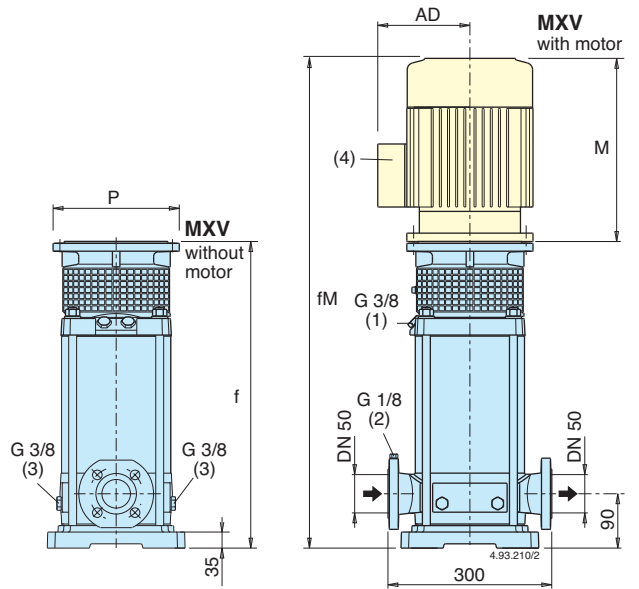
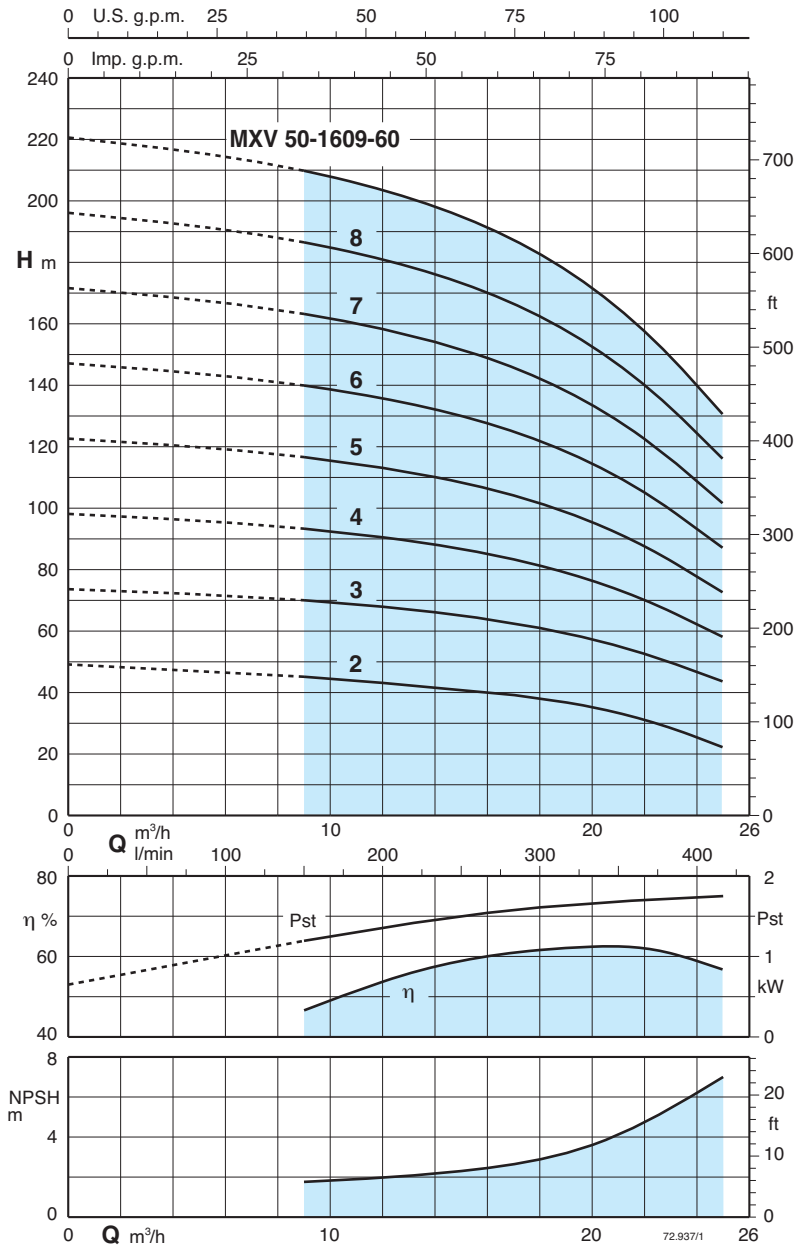

Flanges EN 1092-2 PN 25 - 40

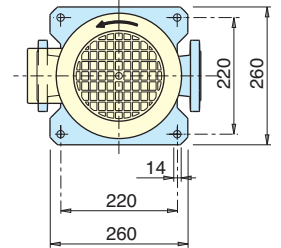
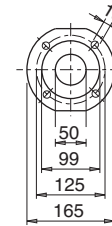

MXV (H) horizontal

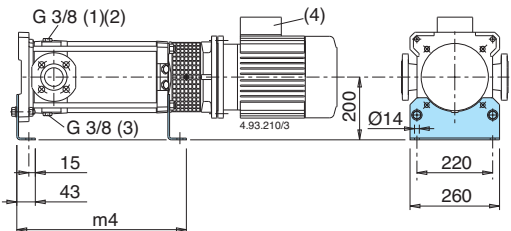

- (1) Filling and air vent
 - (2) Air vent suction side
 - (3) Draining
 - (4) Standard position of terminal box.
- (for other positions rotate motor through 90° or 180°)

Performance

Pump type	Motor power		Motor size	Q m³/h l/min	H								
	kW	HP			0	9	12	14	16	18	20	22	25
MXV 50-1602-60/C	4	5,5	M112V1	0	49	45	43	41	40	38,5	35	31	22
MXV 50-1603-60/C	5,5	7,5	M132V1	0	73	70	68	66	63	61	57	53	44
MXV 50-1604-60/C	7,5	10	M132V1	0	98	93	90	88	85	81	76	70	58
MXV 50-1605-60/C	11	15	M160V1	0	122	117	113	110	106	101	95	88	73
MXV 50-1606-60/C	11	15	M160V1	0	147	140	135	132	128	121	114	105	87
MXV 50-1607-60/C	11	15	M160V1	0	171	164	158	154	149	142	133	122	101
MXV 50-1608-60/C	15	20	M160V1	0	196	187	181	176	170	162	152	140	116
MXV 50-1609-60/C	15	20	M160V1	0	220	210	203	198	192	182	171	158	131

Dimensions mm						Pump weight	
f	M (4)	fM	P	AD (4)	m4	without motor kg (5)	with motor kg (6)
395	311	706	250	137,5	322	42	69,8
415	339	754	300	159,5	322	46	88,3
450	339	789	300	159,5	357	47	94,7
515	434	949	350	186	391	57	133
549	434	983	350	186	426	58	134
583	434	1017	350	186	460	59	135
618	484	1102	350	186	495	61	163
652	484	1136	350	186	529	62	164

Head and power values valid for liquids with density $\rho = 1.0 \text{ kg/dm}^3$ and kinematic viscosity $\nu = \text{max } 20 \text{ mm}^2/\text{sec}$.
 Pst = Power with reference to one stage.

Test results with clean cold water, without gas content.
 A safety margin of + 0.5 m is recommended for the NPSH value.
 Tolerances in accordance with ISO 9906, Annex A.

(5) MXV (N) : + 2 kg
 MXV (H) horizontal : + 3 kg
 (6) With standard motor

Characteristic curves $n \approx 3450$ rpm

Dimensions and weights

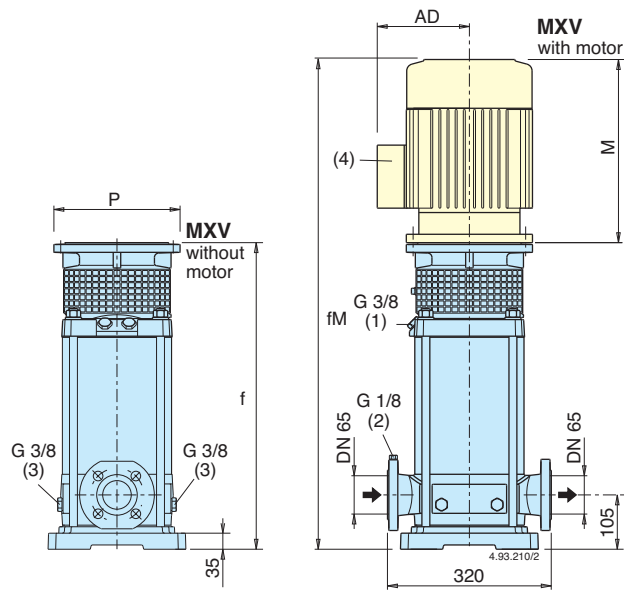
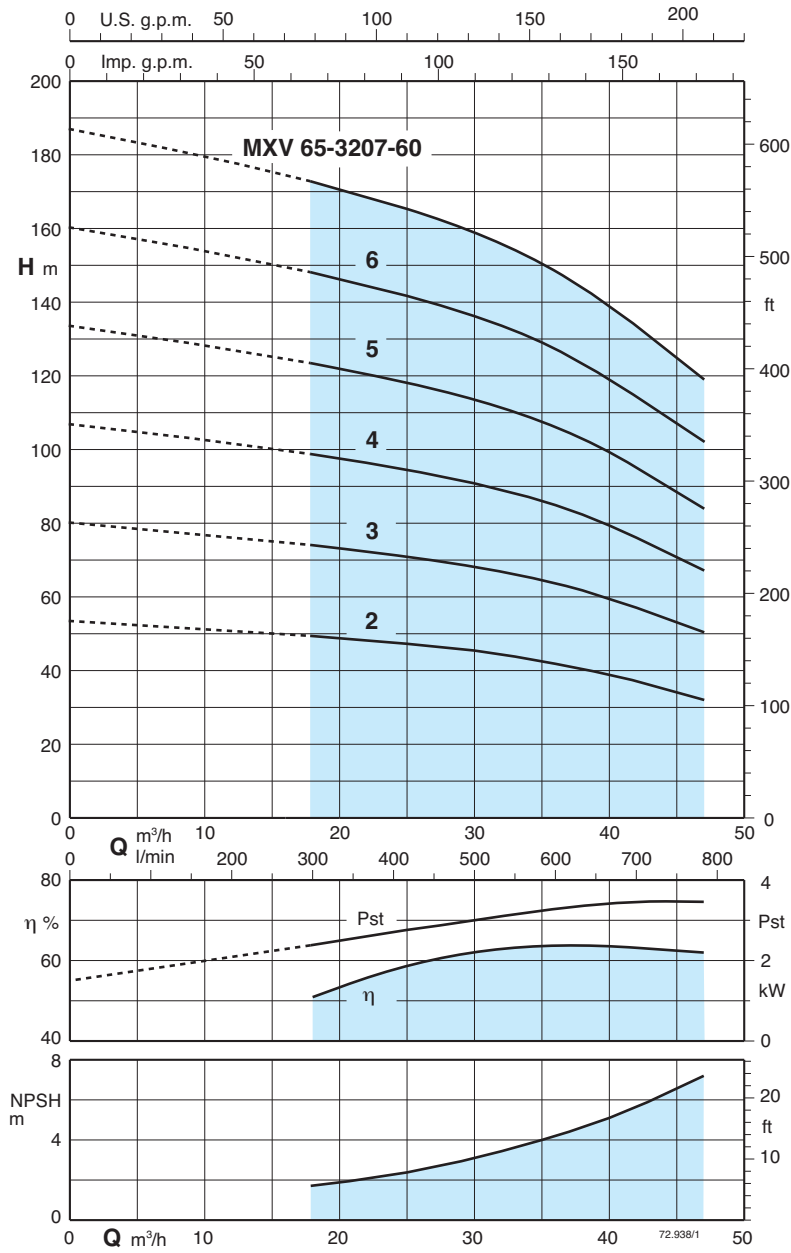

Flanges EN 1092-2 PN 25 - 40

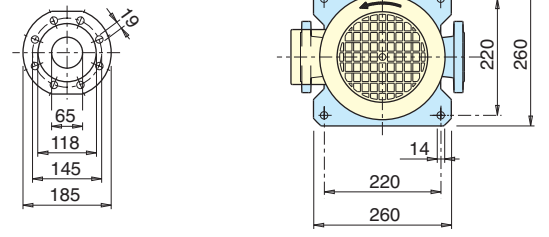

MXV (H) horizontal

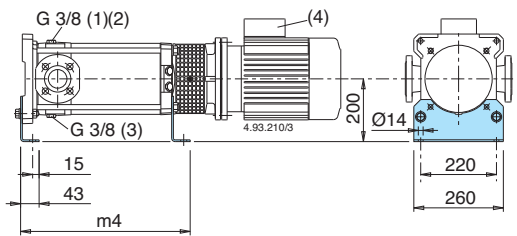

- (1) Filling and air vent
- (2) Air vent suction side
- (3) Draining
- (4) Standard position of terminal box.
(for other positions rotate motor through 90° or 180°)

Performance

Pump type	Motor power		Motor size	Q	Flow rate (Q)										Dimensions (mm)						Pump weight	
	kW	HP			0	18	22	26	30	34	38	42	47	f	M (4)	fM	P	AD (4)	m4	without motor (5)	with motor (6)	
MXV 65-3202-60/C	7,5	10	M132V1	l/min	0	300	366,6	433,3	500	566,6	633,3	700	783,3	427	339	766	300	159,5	334	49	96,7	
MXV 65-3203-60/C	11	15	M160V1		80	74	72	70	68	65	61	57	50	503	434	937	350	186	380	58	134	
MXV 65-3204-60/C	15	20	M160V1		107	99	96	94	91	87	82	76	67	549	484	1033	350	186	426	59	161	
MXV 65-3205-60/C	18,5	25	M160V1		134	124	120	117	114	109	103	95	84	595	510	1105	350	186	472	61	167,5	
MXV 65-3206-60/C	22	30	M180V1		160	148	144	141	136	131	123	115	102	641	538	1179	350	206	518	62	191,3	
MXV 65-3207-60/C	22	30	M180V1	H	187	173	168	164	159	152	144	134	119	687	538	1225	350	206	564	64	193,3	

Head and power values valid for liquids with density $\rho = 1.0$ kg/dm³ and kinematic viscosity $\nu = \max 20$ mm²/sec.
Pst = Power with reference to one stage.

Test results with clean cold water, without gas content.
A safety margin of + 0.5 m is recommended for the NPSH value.
Tolerances in accordance with ISO 9906, Annex A.

(5) MXV (N) : + 2 kg
MXV (H) horizontal : + 3 kg
(6) With standard motor

Characteristic curves n ≈ 3450 rpm

Dimensions and weights

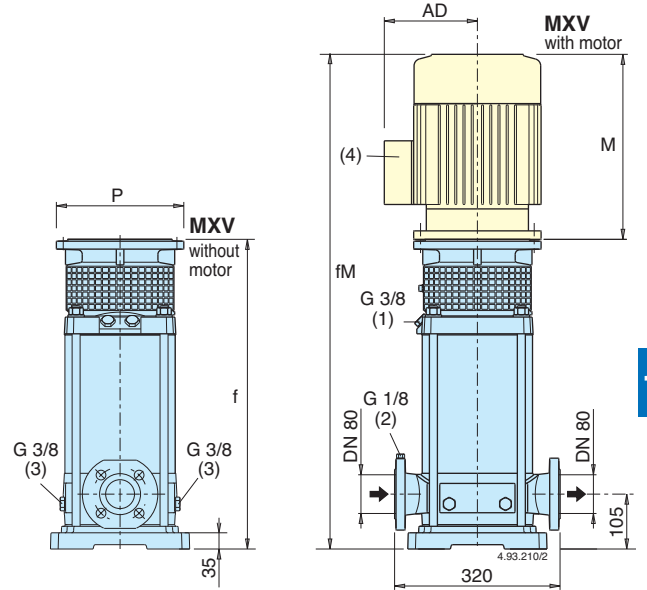
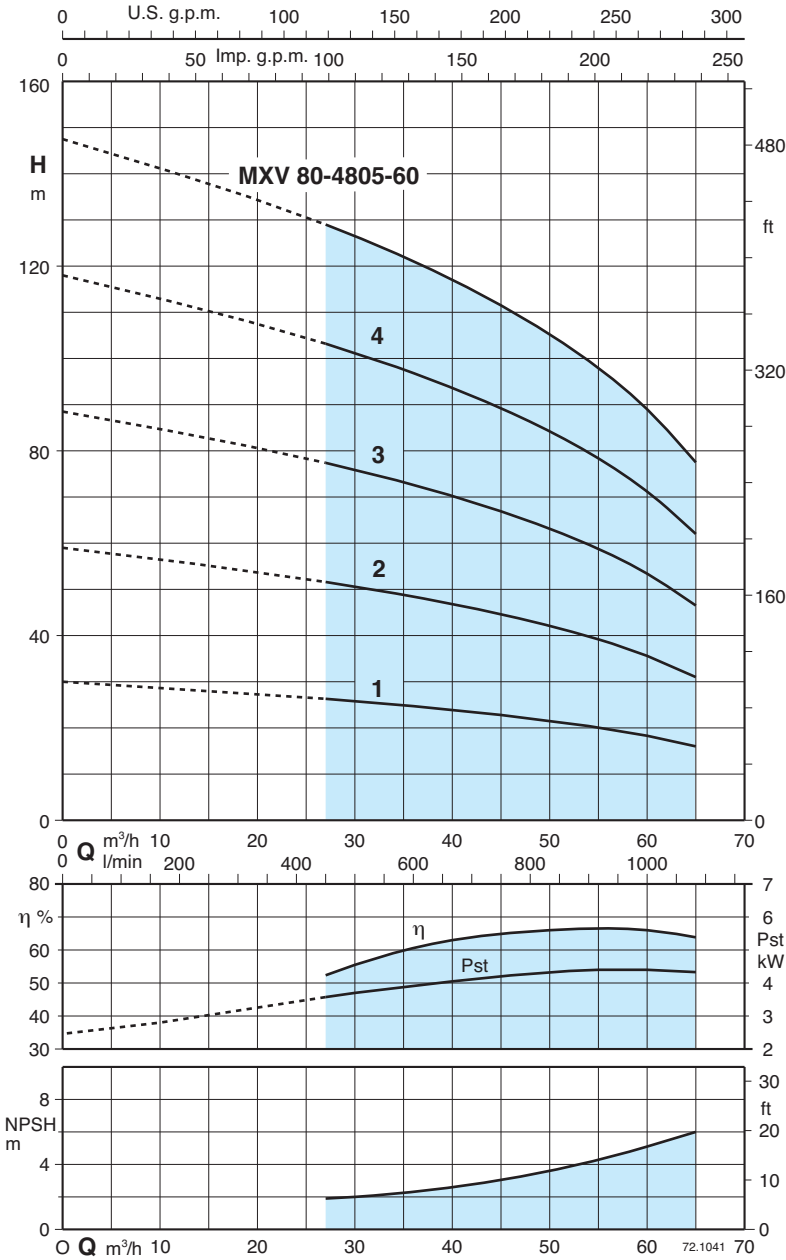

Flanges EN 1092-2 PN 25 - 40

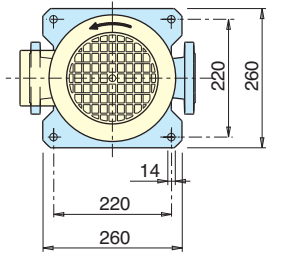
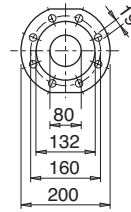

MXV (H) horizontal

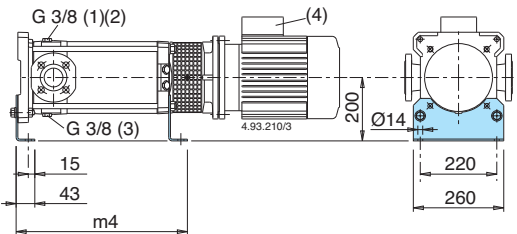

- (1) Filling and air vent
- (2) Air vent suction side
- (3) Draining
- (4) Standard position of terminal box.
(for other positions rotate motor through 90° or 180°)

Performance

Pump type	Motor power		Motor size	Q	Dimensions											Pump weight							
	kW	HP			mm	without motor kg (5)	with motor kg (6)																
					0	27	33	39	45	48	54	60	65	f	M (4)	fM	P	AD (4)	m4				
				l/min	0	450	550	650	750	800	900	1000	1083							kg	kg		
MXV 80-4801-60/C	5,5	7,5	M132V1	H m	30	26	25	24	22,5	22	20	18	16	431	339	770	300	159,5	338	49	91,3		
MXV 80-4802-60/C	11	15	M160V1		59	51,5	49,5	47	44,5	43	40	35,5	31	496	434	930	350	186	373	59	135		
MXV 80-4803-60/C	15	20	M160V1		88,5	77,5	74	70,5	67	64,5	60	53,5	46,5	557	484	1041	350	186	434	61	163		
MXV 80-4804-60/C	18,5	25	M160V1		118	103	99	94	89	86	79,5	71	62	618	510	1128	350	186	495	64	170,5		
MXV 80-4805-60/C	22	30	M180V1		147	129	123	117	111	107	99,5	89	77,5	680	538	1218	350	206	557	66	195,3		

Head and power values valid for liquids with density $\rho = 1.0 \text{ kg/dm}^3$ and kinematic viscosity $\nu = \text{max } 20 \text{ mm}^2/\text{sec}$.
Pst = Power with reference to one stage.

Test results with clean cold water, without gas content.
A safety margin of + 0.5 m is recommended for the NPSH value.
Tolerances in accordance with ISO 9906, Annex A.

(5) MXV (N) : + 2 kg
MXV (H) horizontal : + 3 kg
(6) With standard motor

Characteristic curves $n \approx 1750$ rpm

Dimensions and weights

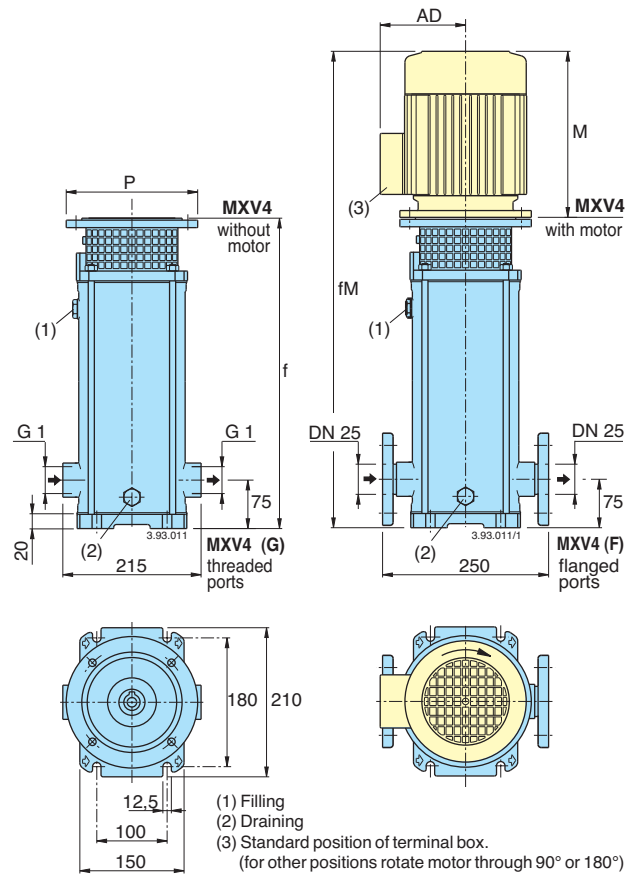
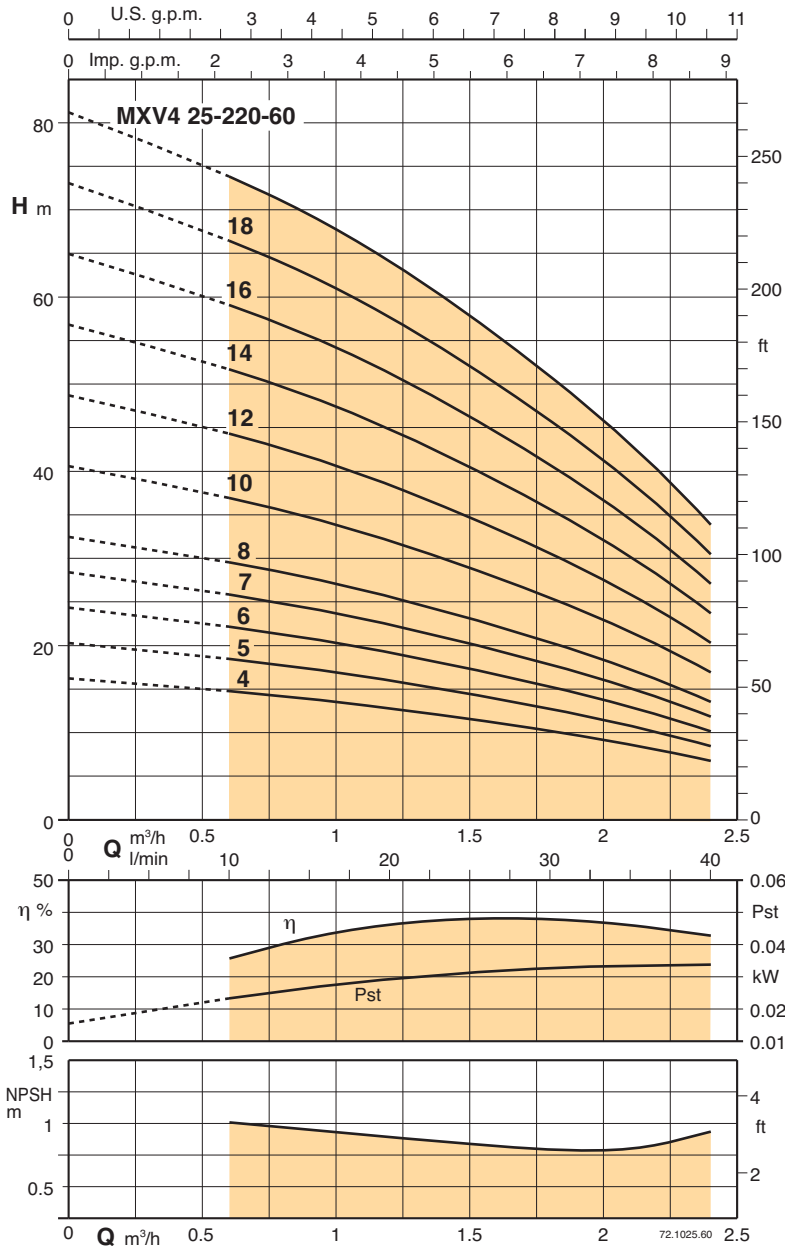

Counterflanges in stainless steel

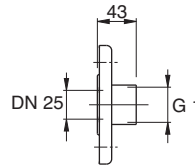

Flanges EN 1092-2 PN 25-40

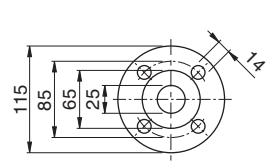

- (4) With standard motor
- (5) Weight MXV4 (G) = weight MXV4 (F) - 1 kg
- (6) Net weight pump with standard motor

Performance

Pump type	Motor power		Motor size	Q	H											
	kW	HP			0	0,6	0,9	1,2	1,5	1,8	2,1	2,4				
MXV4 25-204-60/C	0,55	0,75	M480V1	l/min	0	10	15	20	25	30	35	40				
MXV4 25-205-60/C	0,55	0,75	M480V1		16	15	14	13	11,5	10	9	7				
MXV4 25-206-60/C	0,55	0,75	M480V1		20,5	18,5	17,5	16	14,5	12,5	11	8,5				
MXV4 25-207-60/C	0,55	0,75	M480V1		24,5	22	21	19	17,5	15	13	10				
MXV4 25-208-60/C	0,55	0,75	M480V1		28,5	26	24,5	22,5	20,5	17,5	15,5	12				
MXV4 25-210-60/C	0,55	0,75	M480V1		32,5	29,5	28	25,5	23	20	17,5	13,5				
MXV4 25-212-60/C	0,55	0,75	M480V1		40,5	37	35	32	29	25	22	17				
MXV4 25-214-60/C	0,55	0,75	M480V1		49	44,5	42	38,5	35	30	26,5	20,5				
MXV4 25-214-60/C	0,55	0,75	M480V1		57	52	49	45	40,5	35	31	24				
MXV4 25-216-60/C	0,55	0,75	M480V1		65	59	56	51	46,5	40	35	27				
MXV4 25-218-60/C	0,75	1	M480V1		73	66,5	63	57,5	52	45	39,5	30,5				
MXV4 25-220-60/C	0,75	1	M480V1		81	74	70	64	58	50	44	34				

Dimensions mm					Pump weight	
f	M (4)	fM	P	AD (4)	without motor (5)	with motor (6)
372	255	627	200	127,5	18	30,2
396	255	651	200	127,5	19	31,2
420	255	675	200	127,5	20	32,2
444	255	699	200	127,5	21	33,2
468	255	723	200	127,5	22	34,2
516	255	771	200	127,5	23	35,2
564	255	819	200	127,5	25	37,2
612	255	867	200	127,5	26	41,2
660	255	915	200	127,5	28	43,2
708	255	963	200	127,5	30	45,2
766	255	1021	200	127,5	32	47,2

Head and power values valid for liquids with density $\rho = 1.0 \text{ kg/dm}^3$ and kinematic viscosity $\nu = \text{max } 20 \text{ mm}^2/\text{sec}$.
Pst = Power with reference to one stage.

Test results with clean cold water, without gas content.
A safety margin of + 0.5 m is recommended for the NPSH value.
Tolerances in accordance with ISO 9906, Annex A.

Characteristic curves $n \approx 1750$ rpm

Dimensions and weights

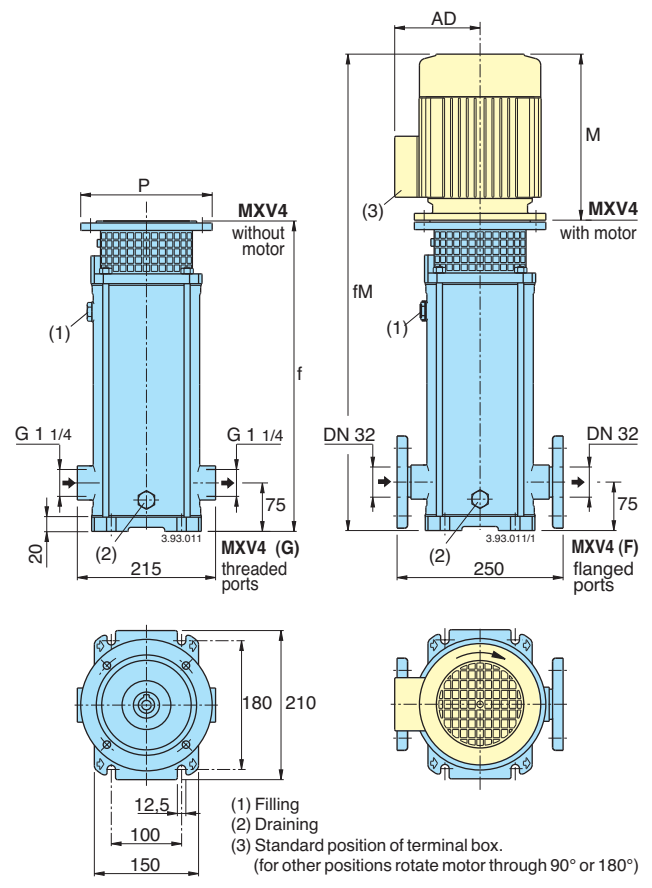
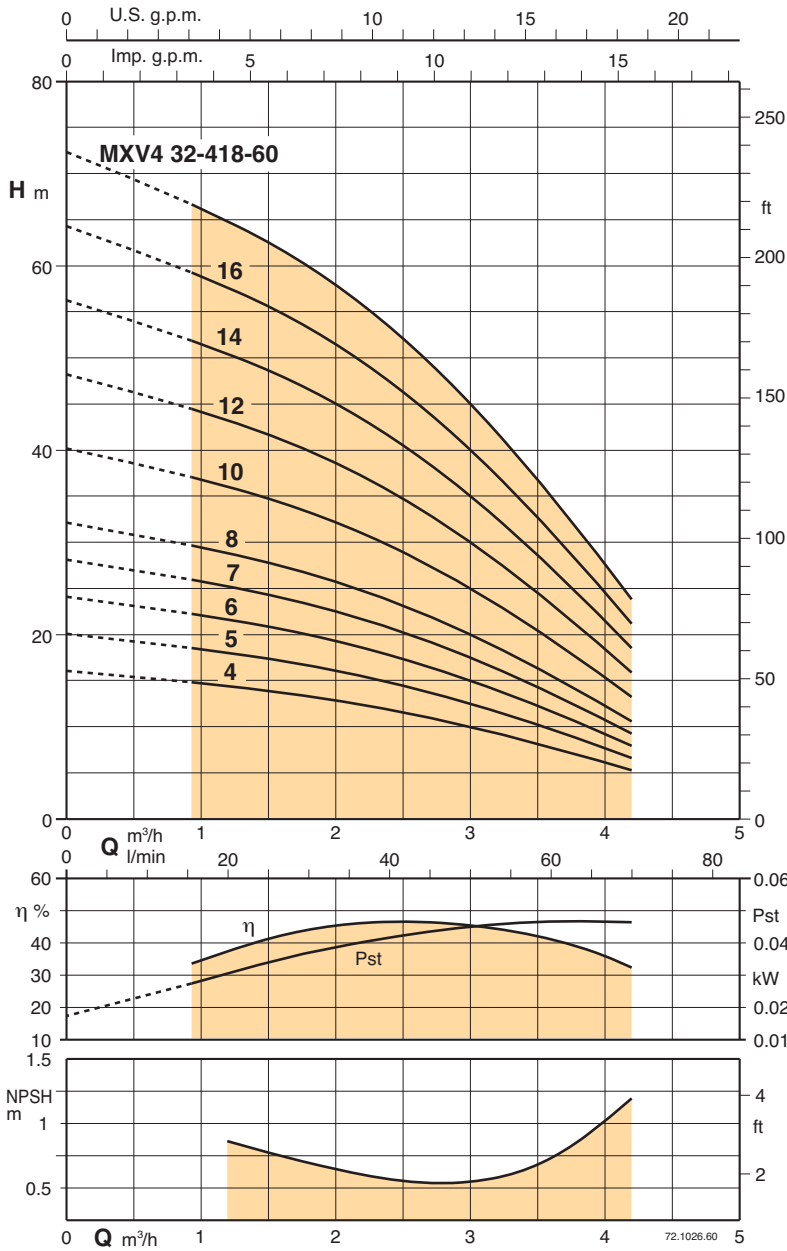

Counterflanges
in stainless steel

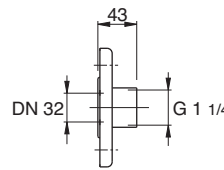

Flanges EN 1092-2
PN 25-40

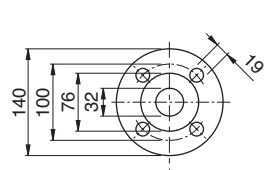

- (4) With standard motor
- (5) Weight MXV4 (G) = weight MXV4 (F) - 1kg
- (6) Net weight pump with standard motor

Performance

Pump type	Motor power		Motor size	Q m³/h l/min	H m										
	kW	HP			0	0,9	1,2	1,8	2,4	3	3,6	4,2			
MXV4 32-404-60/C	0,55	0,75	M480V1	0	16	15	14,5	13,5	12	10	8	5			
MXV4 32-405-60/C	0,55	0,75	M480V1	15	20	18,5	18	16,5	15	12,5	10	6,5			
MXV4 32-406-60/C	0,55	0,75	M480V1	20	24	22	21,5	20	18	15	11,5	8			
MXV4 32-407-60/C	0,55	0,75	M480V1	25	28	26	25	23	20,5	17,5	13,5	9			
MXV4 32-408-60/C	0,55	0,75	M480V1	30	32	29,5	29	26,5	23,5	20	15,5	10,5			
MXV4 32-410-60/C	0,55	0,75	M480V1	35	40	37	36	33,5	29,5	25	19,5	13			
MXV4 32-412-60/C	0,75	1	M480V1	40	48	44,5	43	40	35,5	30	23,5	16			
MXV4 32-414-60/C	0,75	1	M480V1	45	56	52	50,5	46,5	41,5	35	27,5	18,5			
MXV4 32-416-60/C	1,1	1,5	M490V1	50	64	59	57,5	53	47,5	40	31	21			
MXV4 32-418-60/C	1,1	1,5	M490V1	55	72	66,5	65	60	53	45	35	24			

Dimensions mm					Pump weight	
f	M (4)	fM	P	AD (4)	without motor kg (5)	with motor kg (6)
372	255	627	200	127,5	19	31,2
396	255	651	200	127,5	20	32,2
420	255	675	200	127,5	21	33,2
444	255	699	200	127,5	22	34,2
468	255	723	200	127,5	23	35,2
516	255	771	200	127,5	25	37,2
564	255	819	200	127,5	26	41,2
612	255	867	200	127,5	28	43,2
670	295	965	200	127,5	31	49,5
718	295	1013	200	127,5	33	51,5

Head and power values valid for liquids with density $\rho = 1.0 \text{ kg/dm}^3$ and kinematic viscosity $\nu = \text{max } 20 \text{ mm}^2/\text{sec}$.
Pst = Power with reference to one stage.

Test results with clean cold water, without gas content.
A safety margin of + 0.5 m is recommended for the NPSH value.
Tolerances in accordance with ISO 9906, Annex A.

Characteristic curves n ≈ 1750 rpm

Dimensions and weights

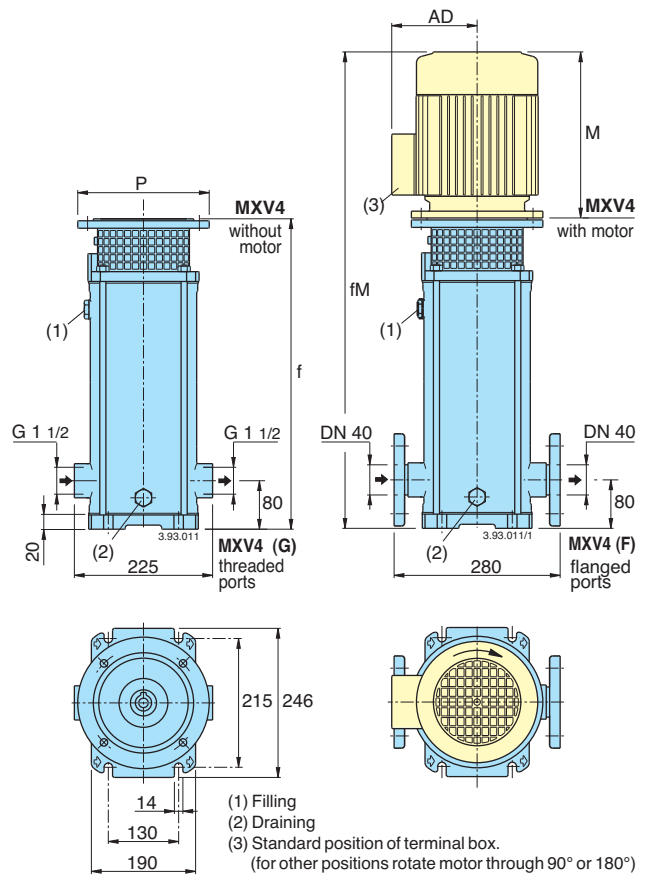
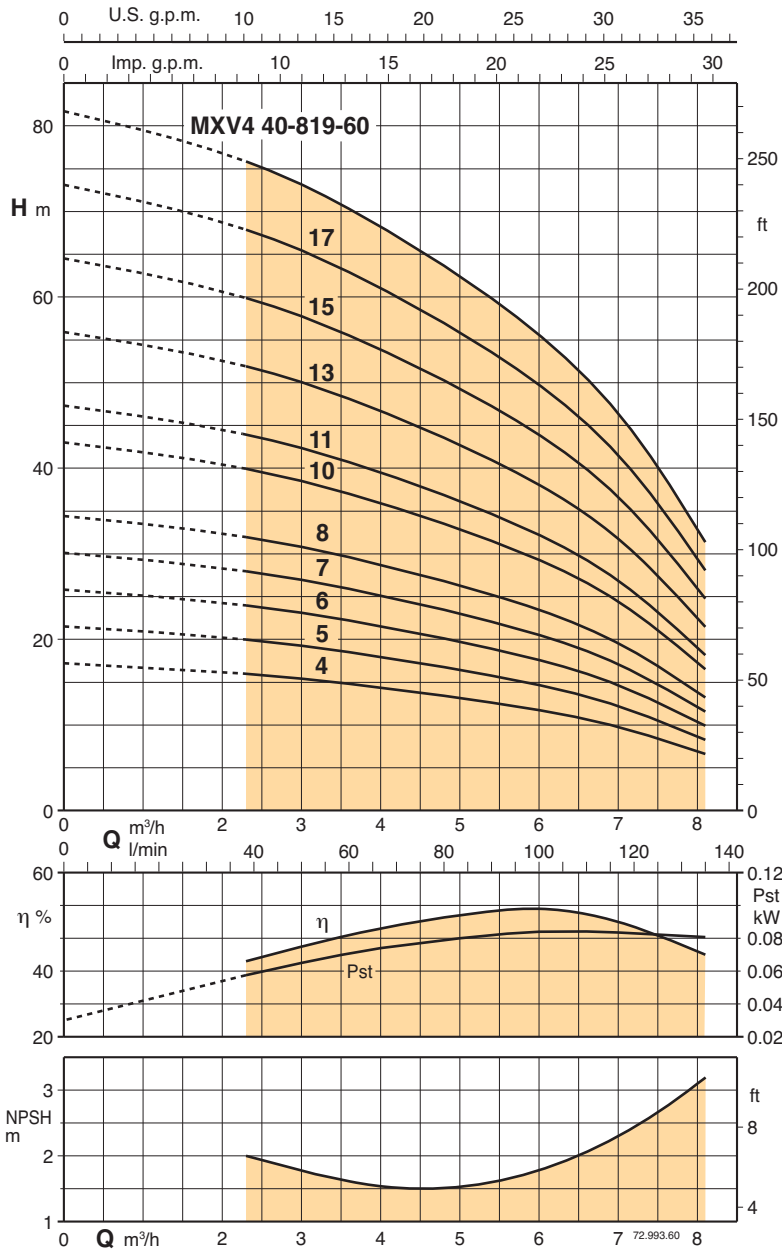

Counterflanges in stainless steel

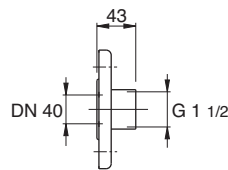

Flanges EN 1092-2 PN 25-40

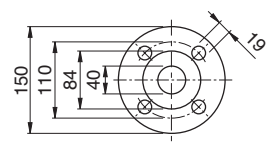

- (4) With standard motor
- (5) Weight MXV4 (G) = weight MXV4 (F) - 1 kg
- (6) Net weight pump with standard motor

Performance

Pump type	Motor power		Motor size	Q m³/h l/min	H										
	kW	HP			0	2,3	3	3,6	4,2	4,8	5,4	6	6,9	8,1	
MXV4 40-804-60/C	0,55	0,75	M480V1	17	16	15,5	15	14	13,5	12,5	11,5	10	6,5		
MXV4 40-805-60/C	0,55	0,75	M480V1	21,5	20	19	18,5	18	17	16	14,5	12,5	8		
MXV4 40-806-60/C	0,55	0,75	M480V1	26	24	23	22	21,5	20	19	17,5	15	10		
MXV4 40-807-60/C	0,75	1	M480V1	30	28	27	26	25	23,5	22	20,5	17,5	11,5		
MXV4 40-808-60/C	0,75	1	M480V1	34,5	32	31	29,5	28,5	27	25	23	20	13		
MXV4 40-810-60/C	1,1	1,5	M490V1	43	40	38,5	37	35,5	33,5	31,5	29	25	16,5		
MXV4 40-811-60/C	1,1	1,5	M490V1	47	44	42,5	41	39	37	34,5	32	27,5	18		
MXV4 40-813-60	1,1	1,5	M490V1	56	52	50	48	46	43,5	41	37,5	32,5	21,5		
MXV4 40-815-60	1,5	2	90 L4	64,5	60	58	55,5	53	50	47	43,5	37,5	24,5		
MXV4 40-817-60	1,5	2	90 L4	73	68	65,5	63	60,5	57	53,5	49	42,5	28		
MXV4 40-819-60	2,2	3	100 L4	82	76	73	70,5	67,5	63,5	60	55	47,5	31,5		

Dimensions mm					Pump weight	
f	M (4)	fM	P	AD (4)	without motor kg (5)	with motor kg (6)
401	255	656	200	127,5	21	33,2
431	255	686	200	127,5	22	34,2
461	255	716	200	127,5	23	35,2
491	255	746	200	127,5	25	40,2
531	255	786	200	127,5	27	42,5
591	295	886	200	127,5	29	47,5
621	295	916	200	127,5	30	48,5
681	295	976	200	127,5	31	49,5
741	282	1023	200	128	33	48
811	282	1093	200	128	34	49
871	313	1184	250	135	39	63

Head and power values valid for liquids with density $\rho = 1.0 \text{ kg/dm}^3$ and kinematic viscosity $\nu = \text{max } 20 \text{ mm}^2/\text{sec}$.
Pst = Power with reference to one stage.

Test results with clean cold water, without gas content.
A safety margin of + 0.5 m is recommended for the NPSH value.
Tolerances in accordance with ISO 9906, Annex A.

Characteristic curves $n \approx 1750$ rpm

Dimensions and weights

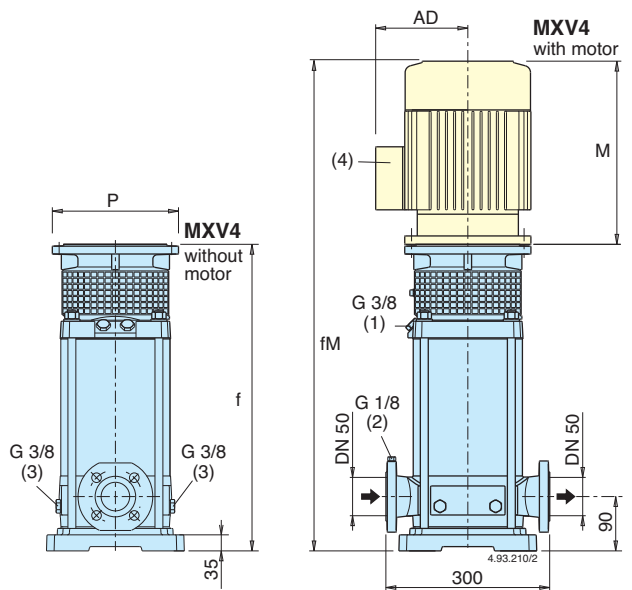
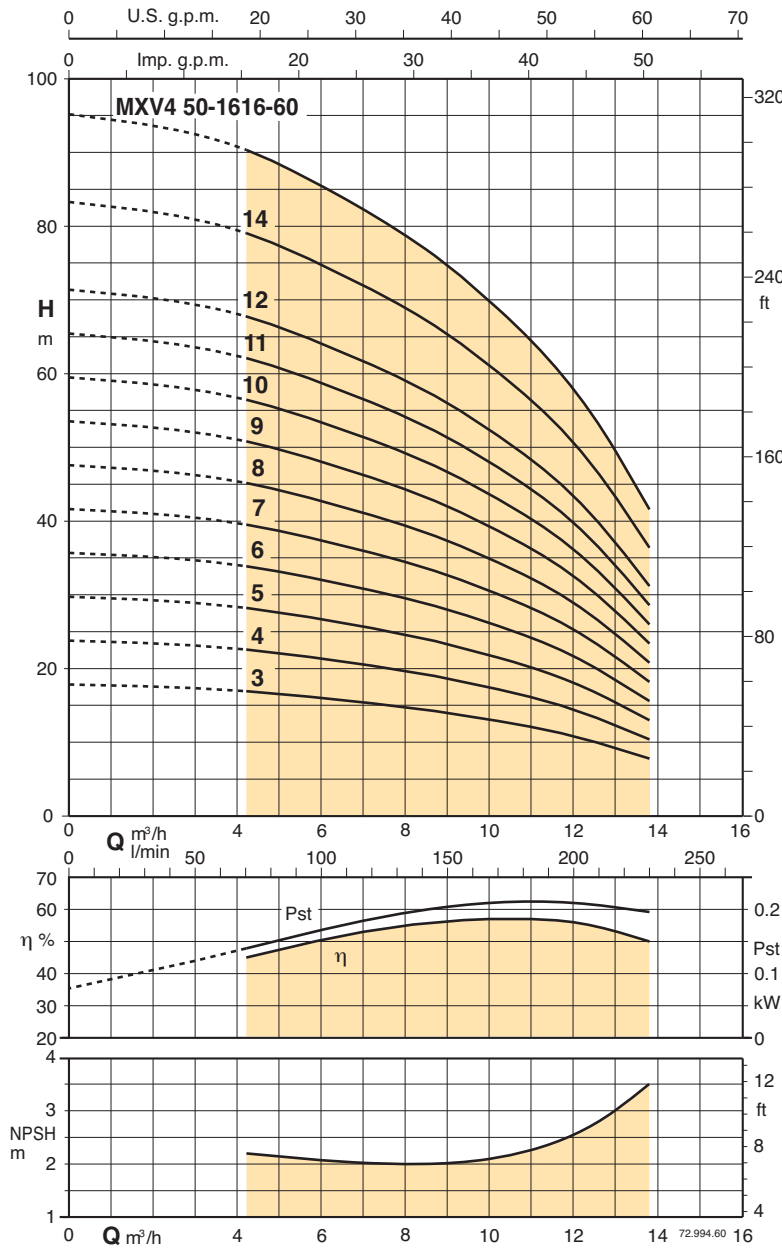

Flanges EN 1092-2 PN 25 - 40

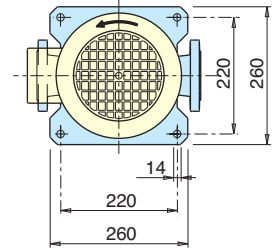
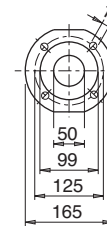

MXV4 (H) horizontal

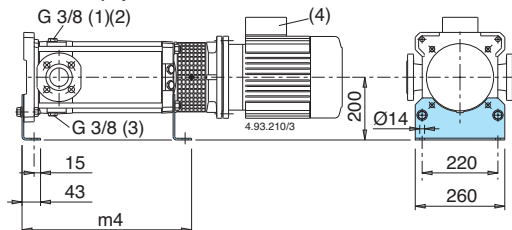

- (1) Filling and air vent
- (2) Air vent suction side
- (3) Draining
- (4) Standard position of terminal box.
(for other positions rotate motor through 90° or 180°)

Performance

Pump type	Motor power		Motor size	Flow rate Q									
	kW	HP		Q m³/h	0	4,2	5,7	7,2	8,7	10,2	11,7	13,8	
				l/min	0	70	95	120	145	170	195	230	
				H m	18	17	16	15,5	14	13	11	8	
MXV4 50-1603-60	2,2	3	100 L4		24	22,5	21,5	20,5	19	17	15	10,5	
MXV4 50-1604-60	2,2	3	100 L4		30	28	27	25,5	24	21,5	19	13	
MXV4 50-1605-60	2,2	3	100 L4		36	34	32,5	30,5	28,5	26	22,5	15,5	
MXV4 50-1606-60	2,2	3	100 L4		41,5	39,5	38	35,5	33	30	26	18	
MXV4 50-1607-60	2,2	3	100 L4		47,5	45	43	41	38	34,5	30	21	
MXV4 50-1608-60	2,2	3	100 L4		53,5	51	48,5	46	43	39	34	23,5	
MXV4 50-1609-60	2,2	3	100 L4		59,5	56,5	54	51	47,5	43	37,5	26	
MXV4 50-1610-60	2,2	3	100 L4		65,5	62	59,5	56	52	47,5	41	28,5	
MXV4 50-1611-60	3	4	100 L4		71,5	68	65	61	57	51,5	45	31	
MXV4 50-1612-60	3	4	100 L4		83,5	79	75,5	71,5	66,5	60	52,5	36,5	
MXV4 50-1614-60	3	4	100 L4		95	90,5	86,5	81,5	76	69	60	41,5	
MXV4 50-1616-60	4	5,5	112 M4										

Dimensions mm						Pump weight	
f	M (4)	fM	P	AD (4)	m4	without motor kg (5)	with motor kg (6)
395	313	708	250	135	322	42	66
430	313	743	250	135	357	43	67
464	313	777	250	135	391	45	69
499	313	812	250	135	426	46	70
533	313	846	250	135	460	48	72
568	313	881	250	135	495	49	73
602	313	915	250	135	529	51	75
637	313	950	250	135	564	52	78
671	313	984	250	135	598	54	80
706	313	1019	250	135	633	55	81
775	313	1068	250	135	702	58	84
844	334	1178	250	148	771	61	92

Head and power values valid for liquids with density $\rho = 1.0 \text{ kg/dm}^3$ and kinematic viscosity $\nu = \text{max } 20 \text{ mm}^2/\text{sec}$.
Pst = Power with reference to one stage.

Test results with clean cold water, without gas content.
A safety margin of + 0.5 m is recommended for the NPSH value.
Tolerances in accordance with ISO 9906, Annex A.

(5) MXV4 (N) : + 2 kg
MXV4 (H) horizontal : + 3 kg
(6) With standard motor

Characteristic curves n ≈ 1750 rpm

Dimensions and weights

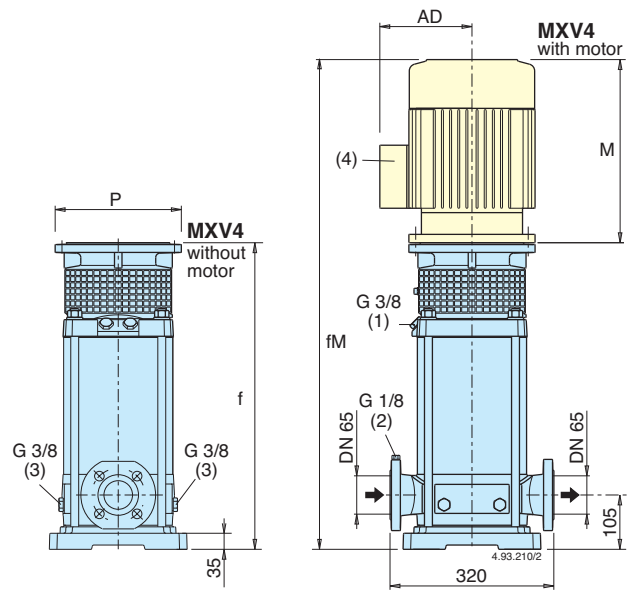
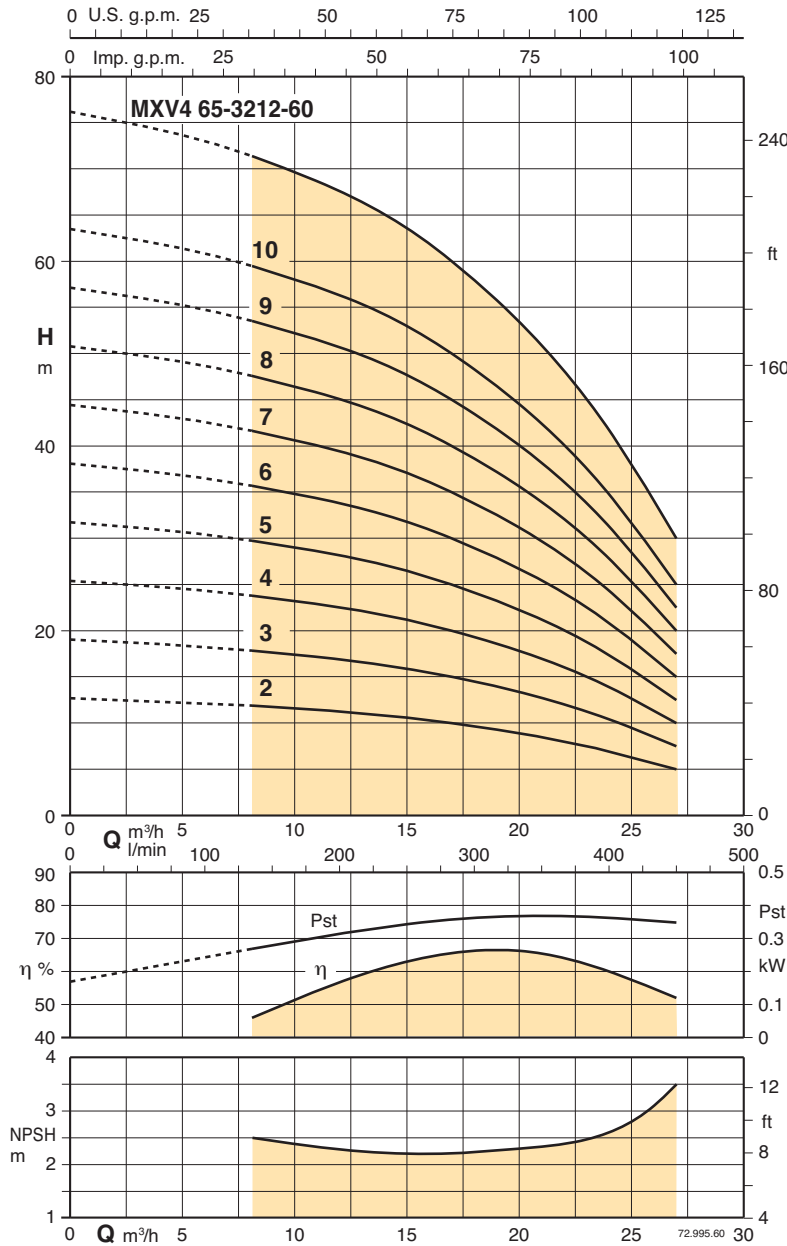

Flanges EN 1092-2 PN 25 - 40

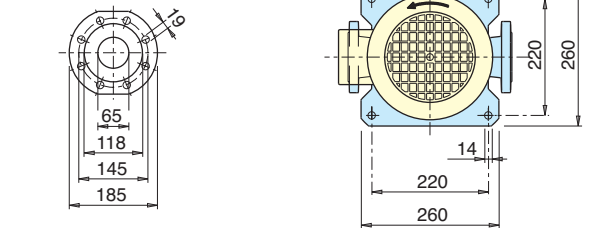

MXV4 (H) horizontal

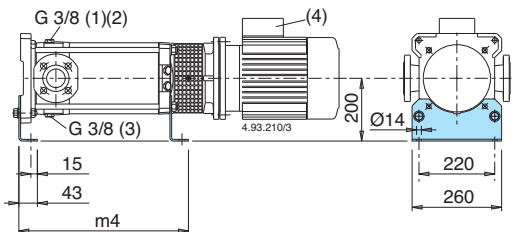

- (1) Filling and air vent
- (2) Air vent suction side
- (3) Draining
- (4) Standard position of terminal box.
(for other positions rotate motor through 90° or 180°)

Performance

Pump type	Motor power		Motor size	Q	Flow rate (m³/h)															
	kW	HP			0	8,1	11	13	15	17	19	23,4	27							
MXV4 65-3202-60	2,2	3	100 L4	l/min	0	135	183,3	216,6	250	283,3	316,6	390	450							
MXV4 65-3203-60	2,2	3	100 L4	H		13	12	11,5	11	10,5	10	9,5	7	5						
MXV4 65-3204-60	2,2	3	100 L4			19	18	17	16,5	16	15	14	11	7,5						
MXV4 65-3205-60	2,2	3	100 L4			25,5	24	23	22	21	20	18,5	14,5	10						
MXV4 65-3206-60	2,2	3	100 L4			32	30	28,5	27,5	26,5	25	23	18	12,5						
MXV4 65-3207-60	3	4	100 L4			38	36	34	33	32	30	28	22	15						
MXV4 65-3208-60	3	4	100 L4			44,5	41,5	40	38,5	37	35	32,5	25,5	17,5						
MXV4 65-3209-60	3	4	100 L4			51	47,5	45,5	44	42,5	40	37	29	20						
MXV4 65-3210-60	4	5,5	112 M4			57	53,5	51,5	49,5	48	45	42	33	22,5						
MXV4 65-3211-60	4	5,5	112 M4			63,5	59,5	57	55	53	50	46,5	36,5	25						
MXV4 65-3212-60	5,5	7,5	132 S4			76	71,5	68,5	66	63,5	60	56	44	30						

Dimensions mm						Pump weight	
f	M (4)	fM	P	AD (4)	m4	without motor kg (5)	with motor kg (6)
407	313	720	250	135	334	45	69
453	313	766	250	135	380	47	71
499	313	812	250	135	426	49	73
545	313	858	250	135	472	51	75
591	313	904	250	135	518	52	78
637	313	950	250	135	564	54	80
683	313	996	250	135	610	56	82
729	334	1063	250	148	656	58	89
795	334	1129	250	148	702	60	91
887	374	1261	300	167	794	67	112

Head and power values valid for liquids with density $\rho = 1.0 \text{ kg/dm}^3$ and kinematic viscosity $\nu = \text{max } 20 \text{ mm}^2/\text{sec}$.
Pst = Power with reference to one stage.

Test results with clean cold water, without gas content.
A safety margin of + 0.5 m is recommended for the NPSH value.
Tolerances in accordance with ISO 9906, Annex A.

(5) MXV4 (N) : + 2 kg
MXV4 (H) horizontal : + 3 kg
(6) With standard motor

Characteristic curves n ≈ 1750 rpm

Dimensions and weights

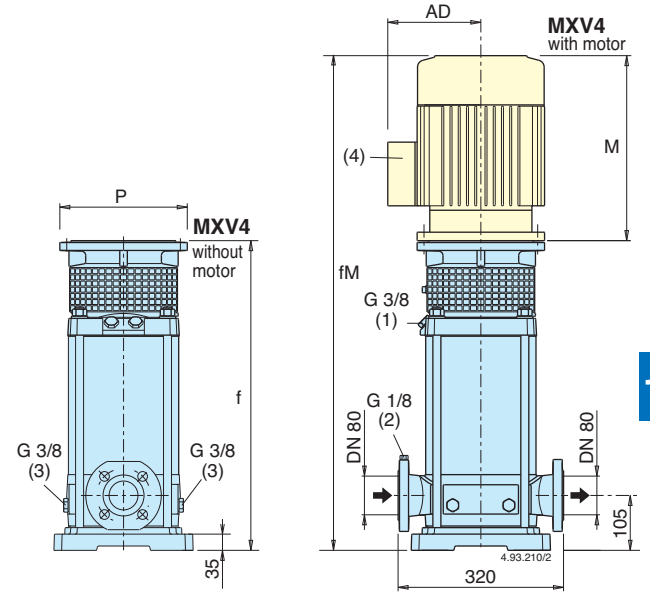
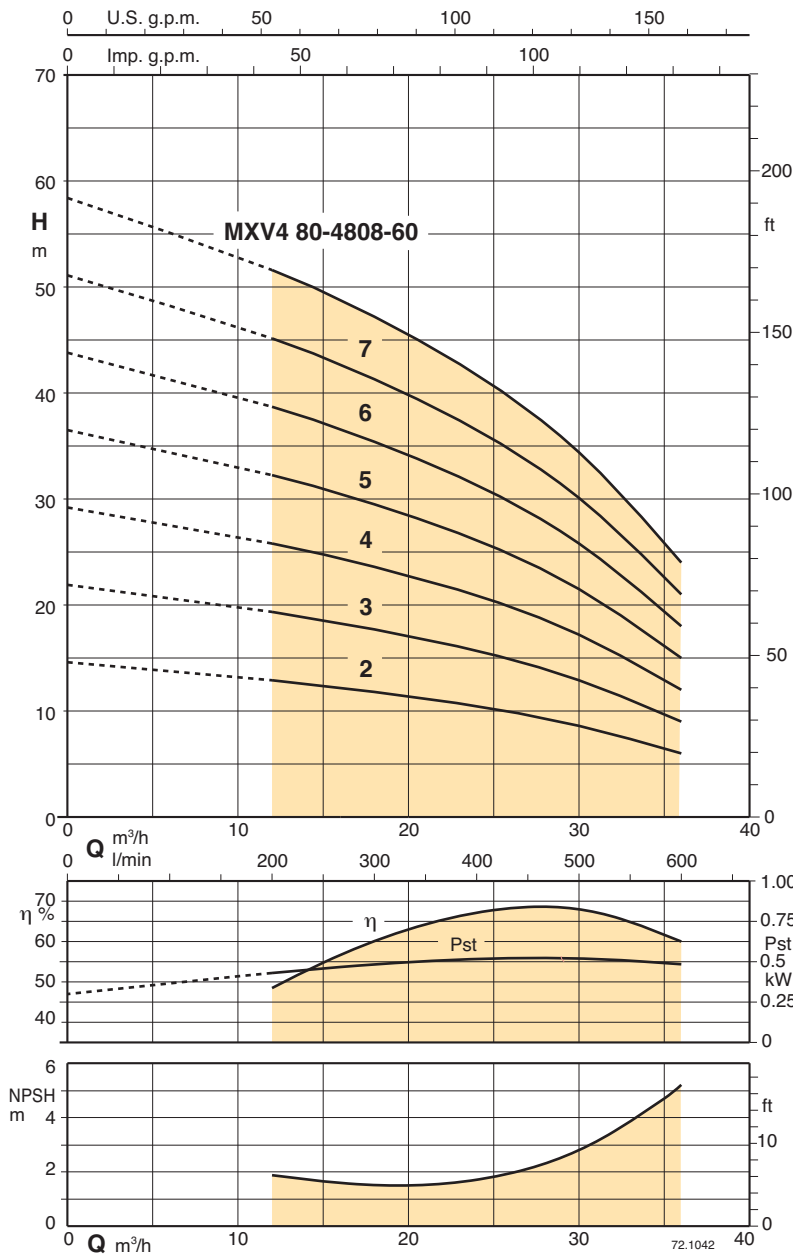

Flanges EN 1092-2 PN 25 - 40

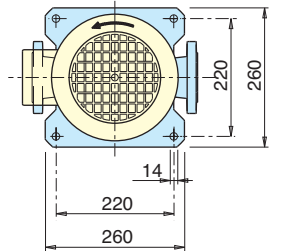
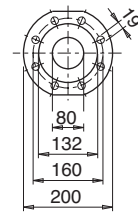

MXV4 (H) horizontal

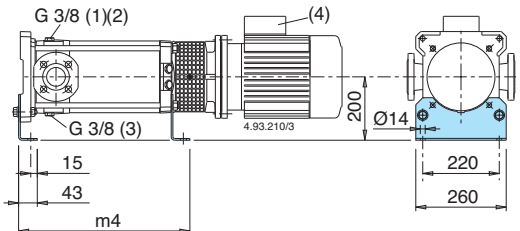

- (1) Filling and air vent
- (2) Air vent suction side
- (3) Draining
- (4) Standard position of terminal box.
(for other positions rotate motor through 90° or 180°)

Performance

Pump type	Motor power		Motor size	Q	H										
	kW	HP			m³/h	0	12	15	18	21	24	27	30	36	
				l/min	0	200	250	300	350	400	450	500	600		
MXV4 80-4802-60	2,2	3	100 LA4		14,5	13	12,5	12	11	10,5	9,5	8,5	6		
MXV4 80-4803-60	2,2	3	100 LA4		22	19,5	18,5	17,5	17	15,5	14,5	13	9		
MXV4 80-4804-60	2,2	3	100 LA4		29	26	25	23,5	22,5	21	19	17	12		
MXV4 80-4805-60	3	4	100 LB4		36,5	32	31	29,5	28	26	24	21,5	15		
MXV4 80-4806-60	3	4	100 LB4		44	39	37	35,5	33,5	31	29	26	18		
MXV4 80-4807-60	4	5,5	112 M4		51	45	43,5	41,5	39	36,5	33,5	30	21		
MXV4 80-4808-60	4	5,5	112 M4		58,5	51,5	49,5	47	45	41,5	38,5	34,5	24		

Dimensions mm						Pump weight	
f	M (4)	fM	P	AD (4)	m4	without motor (5)	with motor (6)
446	313	759	250	135	373	48	72
507	313	820	250	135	434	50	74
568	313	881	250	135	495	53	76
630	313	943	250	135	557	55	81
691	313	1004	250	135	618	58	84
752	334	1086	250	148	679	61	92
834	334	1168	250	148	741	63	94

Head and power values valid for liquids with density $\rho = 1.0 \text{ kg/dm}^3$ and kinematic viscosity $\nu = \text{max } 20 \text{ mm}^2/\text{sec}$.
Pst = Power with reference to one stage.

Test results with clean cold water, without gas content.
A safety margin of + 0.5 m is recommended for the NPSH value.
Tolerances in accordance with ISO 9906, Annex A.

(5) MXV4 (N) : + 2 kg
MXV4 (H) horizontal : + 3 kg
(6) With standard motor

Features

Long Service Life with Standard Motor

Pump with thrust bearing without additional axial loads on the motor bearings.

Any standard motor V1 design (suitable to be lifted in vertical position) can be used, of our choice or of Client's choice.

Easy Assembly of the Motor

With the single-piece sleeve coupling the pump unit can be supplied fully assembled also without the motor. This eliminates the risk of damage caused by shifting of the pump shaft during transportation.

The motor is simply inserted in the coupling and fastened to the flange without the necessity for adapting the axial position of the pump shaft.

Extra Safety

Single-piece coupling guard to be removed only by means of a tool, positioned around the lantern bracket, thus avoiding accidental pushing and rubbing against the coupling.

Low Cost Installation

Vertical construction with reduced pump height for installation in small spaces.

In-line connections to simplify the piping layout with the possibility of inserting the pump in straight pipe-lines.

Disassembly, inspection or cleaning of internal parts without removal of piping.

Robust and Reliable

Single PN 25 construction for all pump sizes.

The suction and discharge nozzles arranged in-line absorb the forces of the piping on the pump without the creation of distorting loads causing local friction and early wears.

The lantern brackets compact and robust design maintains a sure alignment between rotating and fixed parts, reducing vibration.

The upper cover design prevents entrapment of air around the mechanical seal.

Low-Noise Operation

The water filled shroud around the stages and thick external walls, work together for low-noise operation.

Low-noise standard motor.

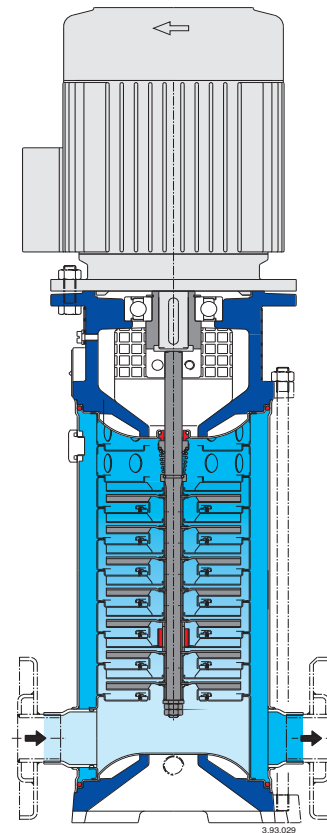

MXV 25-2, 32-4, 40-8

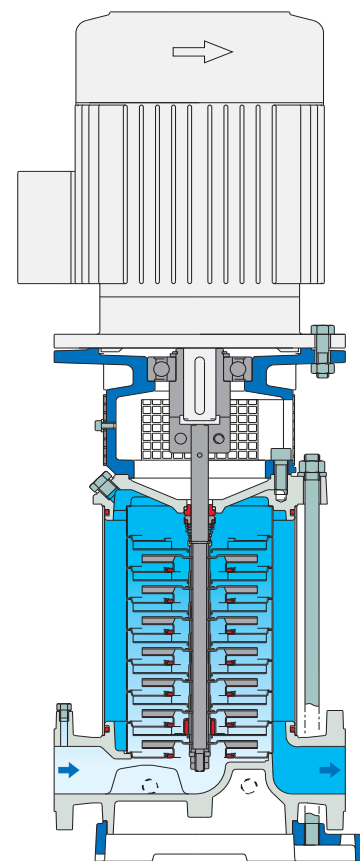

MXV 50-16, 65-32, 80-48



Construction

Vertical multi-stage pumps with suction and delivery connections of the same diameter and arranged along the same axis (in-line). Corrosion-resistant bearing sleeves lubricated by the pumped liquid. A pump with thrust bearing and sleeve coupling for use of any standard motor with IM V1 construction.

Applications

For water supply systems.
For clean non-explosive liquids, without solid, filamentary or abrasive matter (with adaptation of sealing materials on request).
A universal pump for civil and industrial use, for pressure-boosting systems, fire-extinguishing systems, high-pressure washing plants, irrigation, agricultural uses and sport installations.

Operating conditions

Temperature of liquid: from -15 °C to +110 °C.
Operating environment temperature: up to 40 °C.
Maximum permissible pressure in pump casing: 25 bar.

Motor

Standard-type: 2-4 pole induction motor, 60 Hz.
Classification scheme IE2 for three-phase motors from 0,75 kW.
Motor suitable for operation with frequency converter.
Construction IM V1.
Insulation class F.
Protection IP 55.
three-phase with rated voltage: up to 3 kW 220/380 V (IEC 38);
from 4 kW 380/660 V (IEC 38).
Rated speed of rotation (60 Hz): **MXVL** = 3450 rpm
MXVL4 = 1750 rpm.

11.1

MXVL 25-2, 32-4, 40-8

All parts that come into contact with the liquid, including wet-end covers, are in chrome-nickel-molybdenum stainless steel AISI 316L.

Materials (wetted parts)

Component	Material
Flange	Chrome-nickel-molybdenum steel 1.4404 EN 10088 (AISI 316L)
External jacket	
Suction casing	
Delivery casing	
Stage casing	
Impeller	
Lower cover	
Upper cover	
Spacer sleeve	
Pump shaft	Chrome-nickel-molybdenum steel 1.4404 EN 10088 (AISI 316L)
Plug	Corrosion-resistant, cemented carbide Ceramic alumina
Bearing sleeve	
Bearing in stage casing	Hard metal/Carbon/EPDM.
Mechanical seal ISO 3069 - KU	
Wear ring	PTFE
O-rings	NBR

Direction of rotation: clockwise as seen from the motor.

Variants (to be specified when ordering)

- Pump with threaded ports (G).
- Pump with flanged ports (F).
- Pump without motor.
- Pump with standard motor.

Other variants (on request)

- With counter-flanges in chrome-nickel steel.
- O-rings FPM.
- Other mechanical seal.
- Pump with motor of Client's choice (if available).
- Single-phase motor 220 V, up to 2.2 kW.
- Other voltage ratings.
- Higher or lower liquid or ambient temperatures.

MXVL 50-16, 65-32, 80-48

Internal parts in contact with the liquid with pump casing and upper cover in chrome-nickel-molybdenum stainless steel AISI 316L.

Materials (wetted parts)

Component	Material
Pump casing Upper cover	Chrome-nickel-molybdenum steel 1.4404 EN 10088 (AISI 316L)
External jacket	Chrome-nickel-molybdenum steel 1.4404 EN 10088 (AISI 316L)
Stage casing	
Impeller	
Spacer sleeve	
Pump shaft	Chrome-nickel-molybdenum steel 1.4404 EN 10088 (AISI 316L)
Plug	Corrosion-resistant, cemented carbide Ceramic alumina
Bearing sleeve	
Bearing in stage casing	Hard metal/Carbon/EPDM
Mechanical seal ISO 3069 - KU	
Wear ring	PTFE
O-rings	NBR

Direction of rotation: anticlockwise as seen from the motor.

Variants (to be specified when ordering)

- Pump without motor.
- Pump with standard motor.

Other variants (on request)

- O-rings FPM.
- Other mechanical seal.
- Pump with motor of Client's choice (if available).
- Other voltage ratings.
- Pump with support feet for horizontal installation (H1 or H2).
- Support feet for horizontal installation, set.
- Welding counter-flanges, PN 25 (steel).
- Higher or lower liquid or ambient temperatures.

MXVL 25-2, 32-4, 40-8

Designation

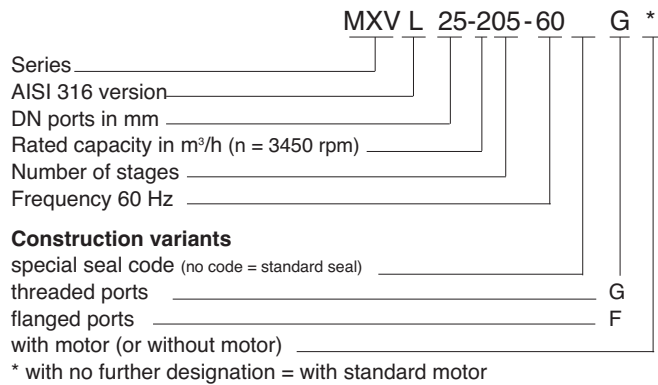

MXVL 50-16, 65-32, 80-48

Designation

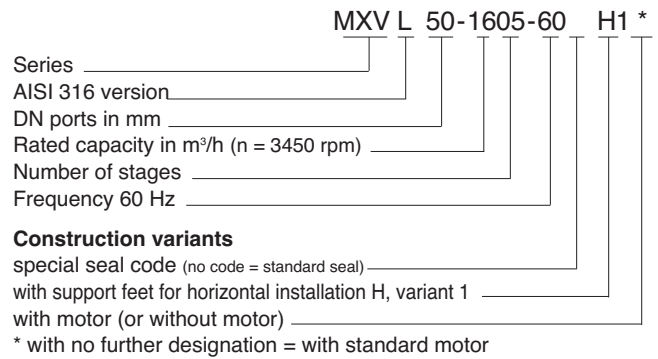

Pipe connection

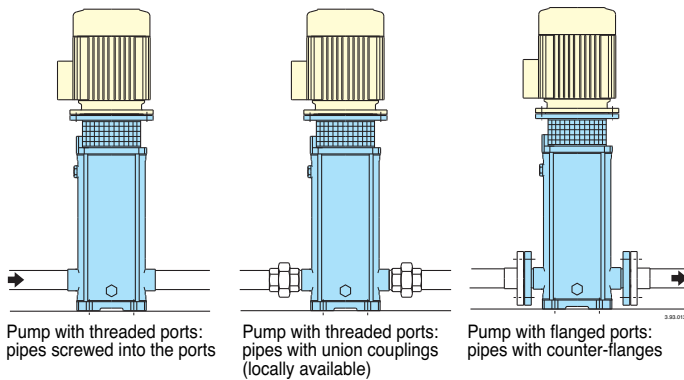

Installations

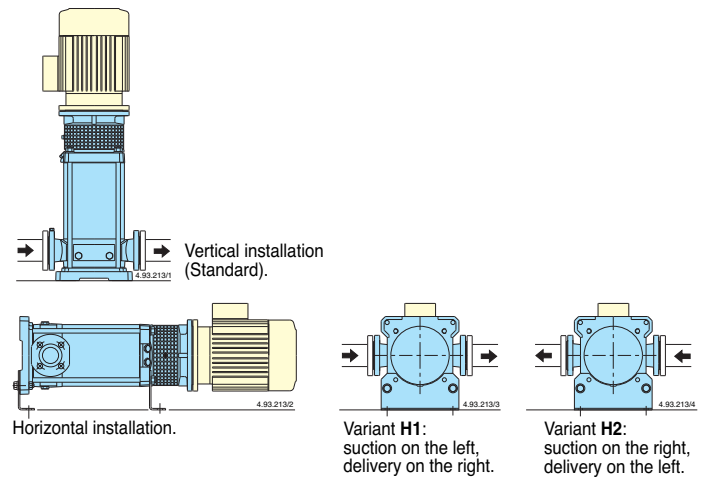

Variable parts

Pump size MXVL - MXVL4			Number of stages	Stage casings with bearing
25 - 203	32 - 403	40 - 803	3	1
25 - 204	32 - 404	40 - 804	4	1
25 - 205	32 - 405	40 - 805	5	1
25 - 206	32 - 406	40 - 806	6	1
25 - 207	32 - 407	40 - 807	7	1
25 - 208	32 - 408	40 - 808	8	1
25 - 210	32 - 410	40 - 810	10	1
25 - 212	32 - 412	40 - 811	11	2
		40 - 813	12	2
25 - 214	32 - 414	40 - 815	13	2
			14	2
25 - 216	32 - 416		15	2
25 - 218	32 - 418		16	2
		40 - 817	17	2
		40 - 819	18	2
25 - 220			19	3
			20	3

Variable parts

Pump size MXVL - MXVL4			Number of stages	Stage casings with bearing
		80 - 4801	1	1
		80 - 4802	2	1
50 - 1603	65 - 3202	80 - 4803	3	1
50 - 1604	65 - 3203	80 - 4804	4	1
50 - 1605	65 - 3204	80 - 4805	5	1
50 - 1606	65 - 3205		6	1
50 - 1607	65 - 3206		7	1
50 - 1608	65 - 3207		8	1
50 - 1609			9	1
50 - 1610			10	1
		80 - 4806	6	2
		80 - 4807	7	2
		80 - 4808	8	2
	65 - 3208		9	2
	65 - 3209		10	2
	65 - 3210		11	2
50 - 1611			12	2
50 - 1612	65 - 3212		13	2
50 - 1614			14	2
50 - 1616			16	2

Coverage chart

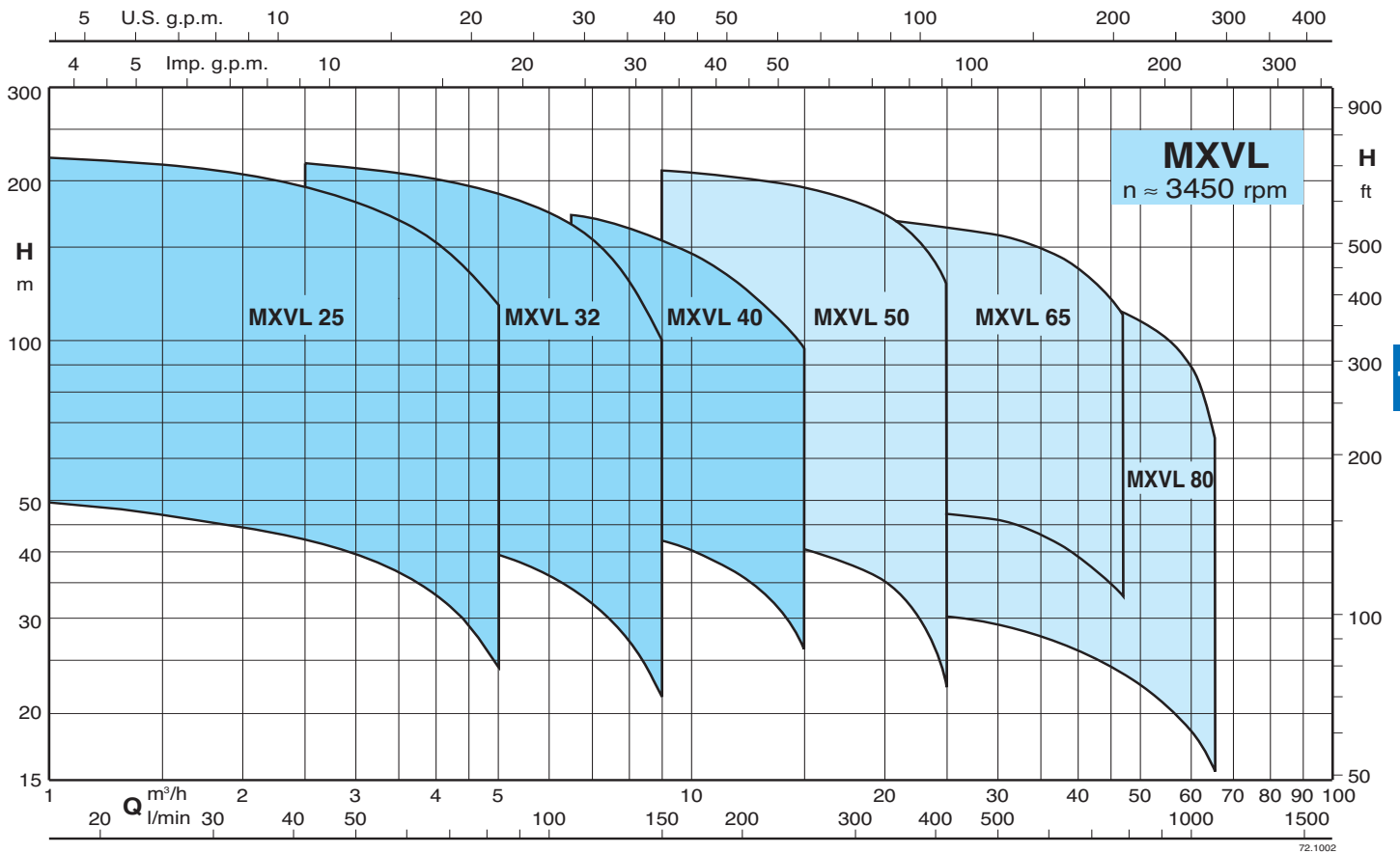

11.1

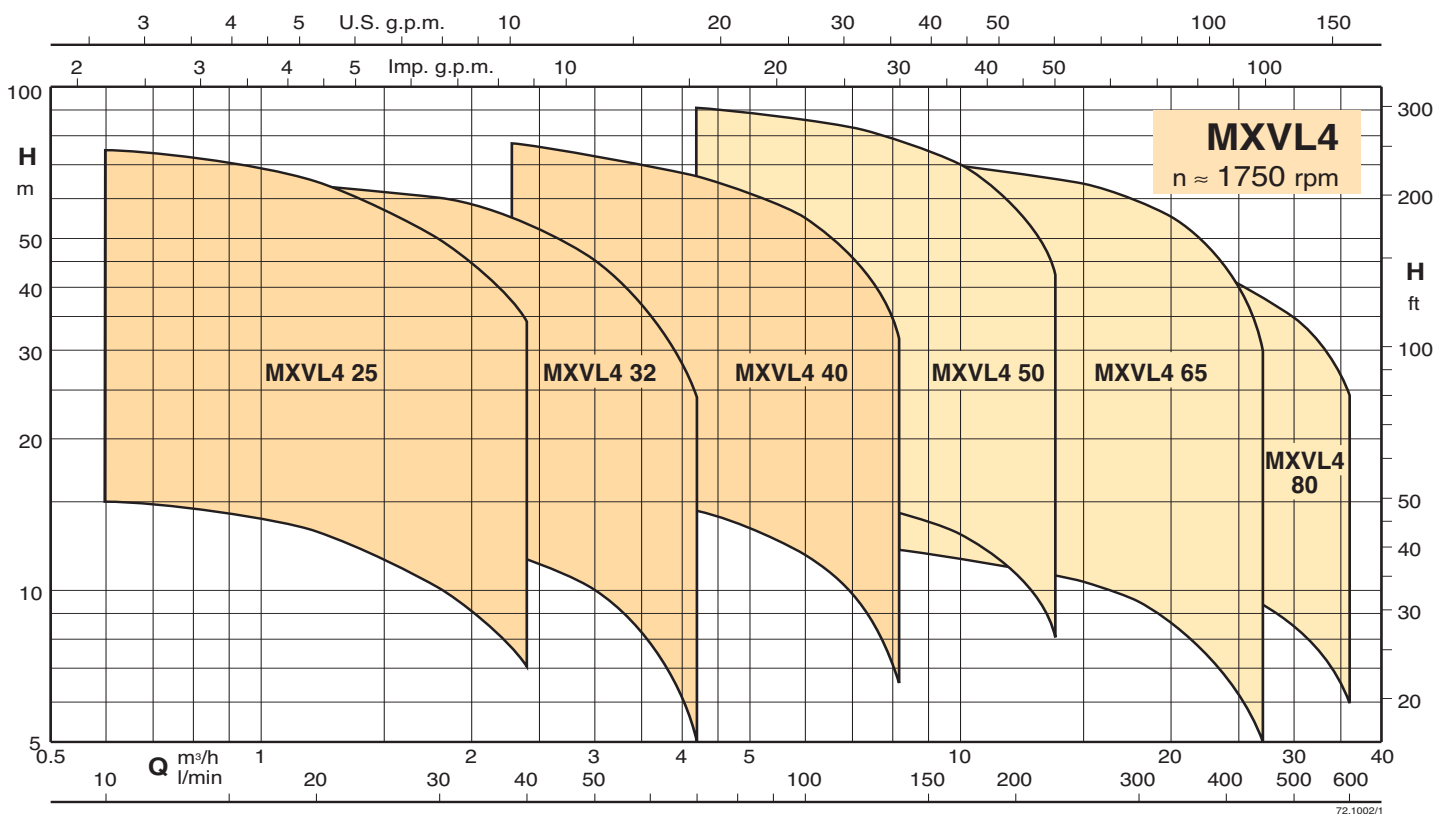

For characteristic curves, dimensions and weights see cap. 11

Features

Long Service Life with Standard Motor

Pump with thrust bearing without additional axial loads on the motor bearings.

Any standard motor V1 design (suitable to be lifted in vertical position) can be used, of our choice or of Client's choice.

Easy Assembly of the Motor

With the single-piece sleeve coupling the pump unit can be supplied fully assembled also without the motor. This eliminates the risk of damage caused by shifting of the pump shaft during transportation.

The motor is simply inserted in the coupling and fastened to the flange without the necessity for adapting the axial position of the pump shaft.

Extra Safety

Single-piece coupling guard to be removed only by means of a tool, positioned around the lantern bracket, thus avoiding accidental pushing and rubbing against the coupling.

Low Cost Installation

Vertical construction with reduced pump height for installation in small spaces.

In-line connections to simplify the piping layout with the possibility of inserting the pump in straight pipe-lines.

Disassembly, inspection or cleaning of internal parts without removal of piping.

Robust and Reliable

Single PN 25 construction for all pump sizes.

The suction and discharge nozzles arranged in-line absorb the forces of the piping on the pump without the creation of distorting loads causing local friction and early wears.

The lantern brackets compact and robust design maintains a sure alignment between rotating and fixed parts, reducing vibration.

The upper cover design prevents entrapment of air around the mechanical seal.

Low-Noise Operation

The water filled shroud around the stages and thick external walls, work together for low-noise operation.

Low-noise standard motor.

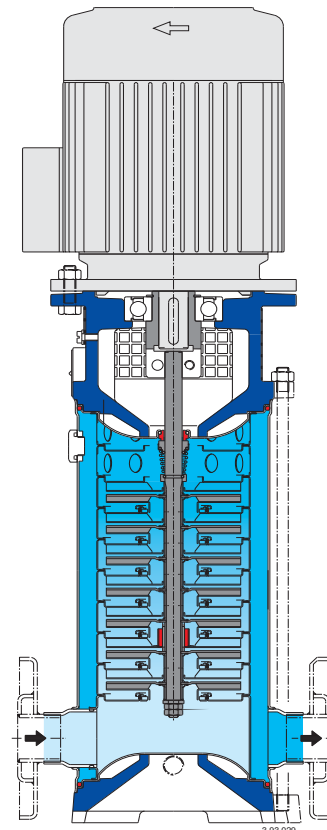

MXVL 25-2, 32-4, 40-8

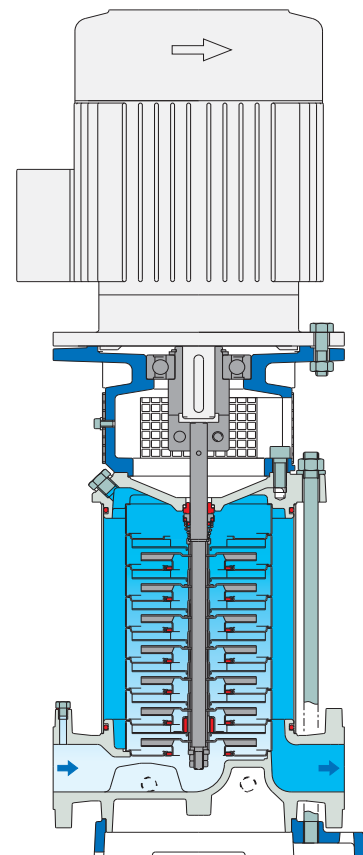

MXVL 50-16, 65-32, 80-48